

**LUNA2000-(97KWH-1H1, 129KWH-2H1,
161KWH-2H1, 200KWH-2H1) Smart String ESS**

Maintenance Manual

Issue 04
Date 2023-06-30



Copyright © Huawei Digital Power Technologies Co., Ltd. 2023. All rights reserved.

No part of this document may be reproduced or transmitted in any form or by any means without prior written consent of Huawei Digital Power Technologies Co., Ltd.

Trademarks and Permissions



HUAWEI and other Huawei trademarks are the property of Huawei Technologies Co., Ltd.

All other trademarks and trade names mentioned in this document are the property of their respective holders.

Notice

The purchased products, services and features are stipulated by the contract made between Huawei Digital Power Technologies Co., Ltd. and the customer. All or part of the products, services and features described in this document may not be within the purchase scope or the usage scope. Unless otherwise specified in the contract, all statements, information, and recommendations in this document are provided "AS IS" without warranties, guarantees or representations of any kind, either express or implied. The information in this document is subject to change without notice. Every effort has been made in the preparation of this document to ensure accuracy of the contents, but all statements, information, and recommendations in this document do not constitute a warranty of any kind, express or implied.

Huawei Digital Power Technologies Co., Ltd.

Address: Huawei Digital Power Antuoshan Headquarters
Futian, Shenzhen 518043
People's Republic of China

Website: <https://digitalpower.huawei.com>

About This Document

Purpose

This document describes routine maintenance, troubleshooting, and parts replacement of LUNA2000-97KWH-1H1, LUNA2000-129KWH-2H1, LUNA2000-161KWH-2H1, and LUNA2000-200KWH-2H1 Smart String Energy Storage Systems (also referred to as ESSs). Before maintaining the ESS, read this document carefully to understand the safety information as well as functions and features of the ESS.



Intended Audience



This document is intended for:

- Technical support engineers
- Maintenance engineers

Symbol Conventions

The symbols that may be found in this document are defined as follows.

Symbol	Description
	Indicates a hazard with a high level of risk which, if not avoided, will result in death or serious injury.
	Indicates a hazard with a medium level of risk which, if not avoided, could result in death or serious injury.
	Indicates a hazard with a low level of risk which, if not avoided, could result in minor or moderate injury.

Symbol	Description
	Indicates a potentially hazardous situation which, if not avoided, could result in equipment damage, data loss, performance deterioration, or unanticipated results. NOTICE is used to address practices not related to personal injury.
	Supplements the important information in the main text. NOTE is used to address information not related to personal injury, equipment damage, and environment deterioration.

Change History

Changes between document issues are cumulative. The latest document issue contains all the changes made in earlier issues.

Issue 04 (2023-06-30)

Updated [About This Document](#).

Issue 03 (2023-06-10)

Updated [4 Replacing a Battery Pack](#).

Added [7 Replacing a Smart PCS](#).

Added [8 Replacing a Smart Rack Controller](#).

Issue 02 (2023-02-28)

Updated [1 Safety Information](#).

Updated [4 Replacing a Battery Pack](#).

Updated [28 Emergency Handling](#).

Updated [29.3 Battery Pack Storage and Single Battery Pack Charge](#).

Issue 01 (2022-10-30)

This issue is used for first office application (FOA).

Contents

About This Document.....	ii
1 Safety Information.....	1
1.1 Personal Safety.....	2
1.2 Electrical Safety.....	4
1.3 Environment Requirements.....	7
1.4 Mechanical Safety.....	9
1.5 Equipment Safety.....	13
1.5.1 ESS Safety.....	14
1.5.2 Battery Safety.....	14
2 Routine Maintenance.....	21
2.1 Preparations Before Maintenance.....	21
2.2 Powering Off a Single ESS.....	22
2.2.1 Sending a Shutdown Command on the SmartLogger.....	22
2.2.2 Power-Off Process.....	23
2.2.3 Power-Off Operations.....	24
2.2.4 Powering Off the Power Supply Loop of the AC Power Distribution Cabinet.....	24
2.3 Routine Maintenance.....	24
2.3.1 Unscheduled Maintenance.....	24
2.3.2 Quarterly Maintenance.....	25
2.3.3 Semi-annual Maintenance.....	26
2.3.4 Annual Maintenance.....	27
3 Alarm Reference.....	28
4 Replacing a Battery Pack.....	29
5 Replacing a Battery Management Module.....	38
6 Replacing a Battery Pack Fan.....	45
7 Replacing a Smart PCS.....	46
8 Replacing a Smart Rack Controller.....	47
9 Replacing a Rack Controller Fan.....	59
10 Replacing an Air Conditioner.....	65

10.1 Replacing an Air Conditioner Internal Fan.....	65
10.2 Replacing an Air Conditioner External Fan.....	68
10.3 Replacing an Air Conditioner Main Control Board.....	70
10.4 Replacing an Air Conditioner.....	74
11 Replacing a Light.....	78
12 Replacing a Fuse.....	79
13 Replacing a Circuit Breaker.....	81
13.1 Replacing a DC Switch.....	81
13.2 Replacing an AC Main Switch.....	84
13.3 Replacing a 220 V Socket Switch.....	85
13.4 Replacing a PSU Switch.....	86
13.5 Replacing a UPS Switch.....	87
13.6 Replacing a DC Power Distribution Switch.....	88
14 Replacing an SPD.....	89
15 Replacing an Emergency Stop Switch.....	91
16 Replacing an Embedded Power Subrack.....	93
17 Replacing a CMU Adapter.....	95
18 Replacing a CMU.....	97
19 Replacing a Door Status Sensor.....	102
20 Replacing a Water Sensor.....	104
21 Replacing a T/H Sensor.....	106
22 Replacing an Exhaust Controller.....	108
23 Replacing a CO Sensor.....	112
24 Replacing an Exhaust Fan.....	114
25 Replacing an SMU11B.....	116
26 Replacing a Smoke Detector.....	118
27 Replacing an I/O Expansion Board.....	120
28 Emergency Handling.....	123
29 FAQ.....	126
29.1 How Do I Recycle Used Batteries?.....	126
29.2 How Do I Repair Paint Damage?.....	127
29.3 Battery Pack Storage and Single Battery Pack Charge.....	131
29.4 How Can I Export Device Logs?.....	136
A Acronyms and Abbreviations.....	137

1 Safety Information

Statement

Before transporting, storing, installing, operating, using, and/or maintaining the equipment, read this document, strictly follow the instructions provided herein, and follow all the safety instructions on the equipment and in this document. In this document, "equipment" refers to the products, software, components, spare parts, and/or services related to this document; "the Company" refers to the manufacturer (producer), seller, and/or service provider of the equipment; "you" refers to the entity that transports, stores, installs, operates, uses, and/or maintains the equipment.

The **Danger, Warning, Caution, and Notice** statements described in this document do not cover all the safety precautions. You also need to comply with relevant international, national, or regional standards and industry practices. **The Company shall not be liable for any consequences that may arise due to violations of safety requirements or safety standards concerning the design, production, and usage of the equipment.**

The equipment shall be used in an environment that meets the design specifications. Otherwise, the equipment may be faulty, malfunctioning, or damaged, which is not covered under the warranty. The Company shall not be liable for any property loss, personal injury, or even death caused thereby.

Comply with applicable laws, regulations, standards, and specifications during transportation, storage, installation, operation, use, and maintenance.

Do not perform reverse engineering, decompilation, disassembly, adaptation, implantation, or other derivative operations on the equipment software. Do not study the internal implementation logic of the equipment, obtain the source code of the equipment software, violate intellectual property rights, or disclose any of the performance test results of the equipment software.

The Company shall not be liable for any of the following circumstances or their consequences:

- The equipment is damaged due to force majeure such as earthquakes, floods, volcanic eruptions, debris flows, lightning strikes, fires, wars, armed conflicts, typhoons, hurricanes, tornadoes, and other extreme weather conditions.
- The equipment is operated beyond the conditions specified in this document.

- The equipment is installed or used in environments that do not comply with international, national, or regional standards.
- The equipment is installed or used by unqualified personnel.
- You fail to follow the operation instructions and safety precautions on the product and in the document.
- You remove or modify the product or modify the software code without authorization.
- You or a third party authorized by you cause the equipment damage during transportation.
- The equipment is damaged due to storage conditions that do not meet the requirements specified in the product document.
- You fail to prepare materials and tools that comply with local laws, regulations, and related standards.
- The equipment is damaged due to your or a third party's negligence, intentional breach, gross negligence, or improper operations, or other reasons not related to the Company.

1.1 Personal Safety

 **DANGER**

Ensure that power is off during installation. Do not install or remove a cable with power on. Transient contact between the core of the cable and the conductor will cause electric arcs, sparks, fire, or explosion, which may result in personal injury.

 **DANGER**

Non-standard and improper operations on the energized equipment may cause fire, electric shocks, or explosion, resulting in property damage, personal injury, or even death.

 **DANGER**

Before operations, remove conductive objects such as watches, bracelets, bangles, rings, and necklaces to prevent electric shocks.

 **DANGER**

During operations, use dedicated insulated tools to prevent electric shocks or short circuits. The dielectric withstanding voltage level must comply with local laws, regulations, standards, and specifications.

 **WARNING**

During operations, wear personal protective equipment such as protective clothing, insulated shoes, goggles, safety helmets, and insulated gloves.

General Requirements

- Do not stop protective devices. Pay attention to the warnings, cautions, and related precautionary measures in this document and on the equipment.
- If there is a likelihood of personal injury or equipment damage during operations, immediately stop, report the case to the supervisor, and take feasible protective measures.
- Do not power on the equipment before it is installed or confirmed by professionals.
- Do not touch the power supply equipment directly or with conductors such as damp objects. Before touching any conductor surface or terminal, measure the voltage at the contact point to ensure that there is no risk of electric shock.
- Do not touch operating equipment because the enclosure is hot.
- Do not touch a running fan with your hands, components, screws, tools, or boards. Otherwise, personal injury or equipment damage may occur.
- In the case of a fire, immediately leave the building or the equipment area and activate the fire alarm or call emergency services. Do not enter the affected building or equipment area under any circumstances.

Personnel Requirements

- Only professionals and trained personnel are allowed to operate the equipment.
 - Professionals: personnel who are familiar with the working principles and structure of the equipment, trained or experienced in equipment operations and are clear of the sources and degree of various potential hazards in equipment installation, operation, maintenance
 - Trained personnel: personnel who are trained in technology and safety, have required experience, are aware of possible hazards on themselves in certain operations, and are able to take protective measures to minimize the hazards on themselves and other people
- Personnel who plan to install or maintain the equipment must receive adequate training, be able to correctly perform all operations, and understand all necessary safety precautions and local relevant standards.
- Only qualified professionals or trained personnel are allowed to install, operate, and maintain the equipment.
- Only qualified professionals are allowed to remove safety facilities and inspect the equipment.
- Personnel who will perform special tasks such as electrical operations, working at heights, and operations of special equipment must possess the required local qualifications.
- Only certified high-voltage electricians are allowed to operate medium-voltage equipment.

- Only authorized professionals are allowed to replace the equipment or components (including software).
- Only personnel who need to work on the equipment are allowed to access the equipment.

1.2 Electrical Safety

 **DANGER**

Before connecting cables, ensure that the equipment is intact. Otherwise, electric shocks or fire may occur.

 **DANGER**

Non-standard and improper operations may result in fire or electric shocks.

 **DANGER**

Prevent foreign matter from entering the equipment during operations. Otherwise, equipment damage, load power derating, power failure, or personal injury may occur.

 **WARNING**

For the equipment that needs to be grounded, install the ground cable first when installing the equipment and remove the ground cable last when removing the equipment.

 **CAUTION**

Do not route cables near the air intake or exhaust vents of the equipment.

General Requirements

- Follow the procedures described in the document for installation, operation, and maintenance. Do not reconstruct or alter the equipment, add components, or change the installation sequence without permission.
- Obtain approval from the national or local electric utility company before connecting the equipment to the grid.
- Observe the power plant safety regulations, such as the operation and work ticket mechanisms.
- Install temporary fences or warning ropes and hang "No Entry" signs around the operation area to keep unauthorized personnel away from the area.

- Before installing or removing power cables, turn off the switches of the equipment and its upstream and downstream switches.
- If any liquid is detected inside the equipment, disconnect the power supply immediately and do not use the equipment.
- Before performing operations on the equipment, check that all tools meet the requirements and record the tools. After the operations are complete, collect all of the tools to prevent them from being left inside the equipment.
- Before installing power cables, check that cable labels are correct and cable terminals are insulated.
- When installing the equipment, use a torque tool of a proper measurement range to tighten the screws. When using a wrench to tighten the screws, ensure that the wrench does not tilt and the torque error does not exceed 10% of the specified value.
- Ensure that bolts are tightened with a torque tool and marked in red and blue after double-check. Installation personnel mark tightened bolts in blue. Quality inspection personnel confirm that the bolts are tightened and then mark them in red. (The marks must cross the edges of the bolts.)

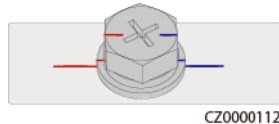

- After the installation is complete, ensure that protective cases, insulation tubes, and other necessary items for all electrical components are in position to avoid electric shocks.
- If the equipment has multiple inputs, disconnect all the inputs before operating the equipment.
- Before maintaining a downstream electrical or power distribution device, turn off the output switch on the power supply equipment.
- During equipment maintenance, attach "Do not switch on" labels near the upstream and downstream switches or circuit breakers as well as warning signs to prevent accidental connection. The equipment can be powered on only after troubleshooting is complete.
- If fault diagnosis and troubleshooting need to be performed after power-off, take the following safety measures: Disconnect the power supply. Check whether the equipment is live. Install a ground cable. Hang warning signs and set up fences.
- Check equipment connections periodically, ensuring that all screws are securely tightened.
- Only qualified professionals can replace a damaged cable.
- Do not scrawl, damage, or block any labels or nameplates on the equipment. Promptly replace labels that have worn out.
- Do not use solvents such as water, alcohol, or oil to clean electrical components inside or outside of the equipment.

Grounding

- Ensure that the grounding impedance of the equipment complies with local electrical standards.

- Ensure that the equipment is connected permanently to the protective ground. Before operating the equipment, check its electrical connection to ensure that it is reliably grounded.
- Do not work on the equipment in the absence of a properly installed ground conductor.
- Do not damage the ground conductor.
- For the equipment that uses a three-pin socket, ensure that the ground terminal in the socket is connected to the protective ground point.
- If high touch current may occur on the equipment, ground the protective ground terminal on the equipment enclosure before connecting the power supply; otherwise, electric shock as a result of touch current may occur.

Cabling Requirements

- When selecting, installing, and routing cables, follow local safety regulations and rules.
- When routing power cables, ensure that there is no coiling or twisting. Do not join or weld power cables. If necessary, use a longer cable.
- Ensure that all cables are properly connected and insulated, and meet specifications.
- Ensure that the slots and holes for routing cables are free from sharp edges, and that the positions where cables are routed through pipes or cable holes are equipped with cushion materials to prevent the cables from being damaged by sharp edges or burrs.
- If a cable is routed into the cabinet from the top, bend the cable in a U shape outside the cabinet and then route it into the cabinet.
- Ensure that cables of the same type are bound together neatly and straight and that the cable sheath is intact. When routing cables of different types, ensure that they are at least 30 mm away from each other.
- When cable connection is completed or paused for a short period of time, seal the cable holes with sealing putty immediately to prevent small animals or moisture from entering.
- Secure buried cables using cable supports and cable clips. Ensure that the cables in the backfill area are in close contact with the ground to prevent cable deformation or damage during backfilling.
- If the external conditions (such as the cable layout or ambient temperature) change, verify the cable usage in accordance with the IEC-60364-5-52 or local laws and regulations. For example, check that the current-carrying capacity meets requirements.
- When routing cables, reserve at least 30 mm clearance between the cables and heat-generating components or areas. This prevents deterioration or damage to the cable insulation layer.
- When the temperature is low, violent impact or vibration may damage the plastic cable sheathing. To ensure safety, comply with the following requirements:
 - Cables can be laid or installed only when the temperature is higher than 0°C. Handle cables with caution, especially at a low temperature.
 - Cables stored at subzero temperatures must be stored at room temperature for at least 24 hours before they are laid out.

- Do not perform any improper operations, for example, dropping cables directly from a vehicle. Otherwise, the cable performance may deteriorate due to cable damage, which affects the current-carrying capacity and temperature rise.

ESD

NOTICE

The static electricity generated by human bodies may damage the electrostatic-sensitive components on boards, for example, the large-scale integrated (LSI) circuits.

- When touching the equipment and handling boards, modules with exposed circuit boards, or application-specific integrated circuits (ASICs), observe ESD protection regulations and wear ESD clothing and ESD gloves or a well-grounded ESD wrist strap.

Figure 1-1 Wearing an ESD wrist strap

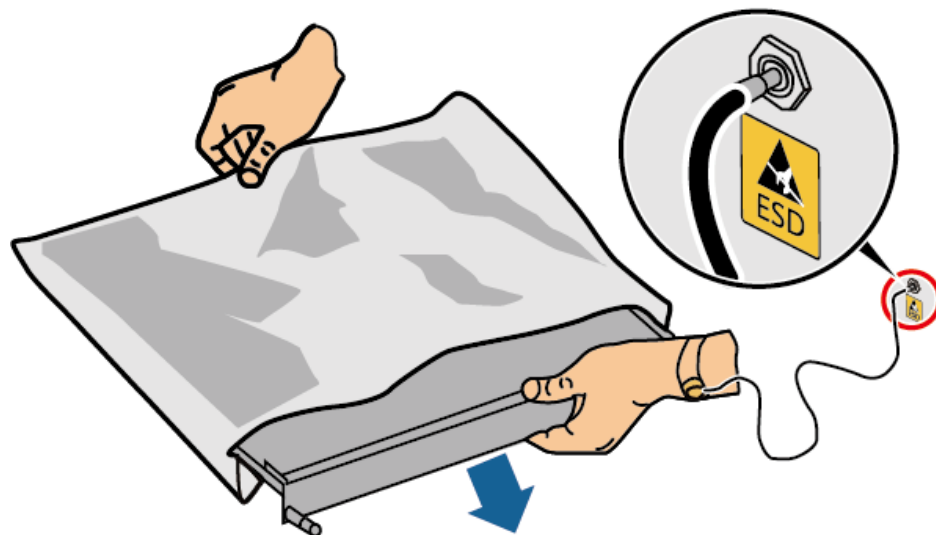

DC15000001

- When holding a board or a module with exposed circuit boards, hold its edge without touching any components. Do not touch the components with bare hands.
- Package boards or modules with ESD packaging materials before storing or transporting them.

1.3 Environment Requirements

DANGER

Do not expose the equipment to flammable or explosive gas or smoke. Do not perform any operation on the equipment in such environments.

 **DANGER**

Do not store any flammable or explosive materials in the equipment area.

 **DANGER**

Do not place the equipment near heat sources or fire sources, such as smoke, candles, heaters, or other heating devices. Overheat may damage the equipment or cause a fire.

 **WARNING**

Install the equipment in an area far away from liquids. Do not install it under areas prone to condensation, such as under water pipes and air exhaust vents, or areas prone to water leakage, such as air conditioner vents, ventilation vents, or feeder windows of the equipment room. Ensure that no liquid enters the equipment to prevent faults or short circuits.

 **WARNING**

To prevent damage or fire due to high temperature, ensure that the ventilation vents or heat dissipation systems are not obstructed or covered by other objects while the equipment is running.

General Requirements

- Ensure that the equipment is stored in a clean, dry, and well ventilated area with proper temperature and humidity and is protected from dust and condensation.
- Keep the installation and operating environments of the equipment within the allowed ranges. Otherwise, its performance and safety will be compromised.
- Do not install, use, or operate outdoor equipment and cables (including but not limited to moving equipment, operating equipment and cables, inserting connectors to or removing connectors from signal ports connected to outdoor facilities, working at heights, performing outdoor installation, and opening doors) in harsh weather conditions such as lightning, rain, snow, and level 6 or stronger wind.
- Do not install the equipment in an environment with dust, smoke, volatile or corrosive gases, infrared and other radiations, organic solvents, or salty air.
- Do not install the equipment in an environment with conductive metal or magnetic dust.
- Do not install the equipment in an area conducive to the growth of microorganisms such as fungus or mildew.
- Do not install the equipment in an area with strong vibration, noise, or electromagnetic interference.

- Ensure that the site complies with local laws, regulations, and related standards.
- Ensure that the ground in the installation environment is solid, free from spongy or soft soil, and not prone to subsidence. The site must not be located in a low-lying land prone to water or snow accumulation, and the horizontal level of the site must be above the highest water level of that area in history.
- Do not install the equipment in a position that may be submerged in water.
- If the equipment is installed in a place with abundant vegetation, in addition to routine weeding, harden the ground underneath the equipment using cement or gravel.
- Before opening doors during the installation, operation, and maintenance of the equipment, clean up any water, ice, snow, or other foreign objects on the top of the equipment to prevent foreign objects from falling into the equipment.
- When installing the equipment, ensure that the installation surface is solid enough to bear the weight of the equipment.
- All cable holes must be sealed. Seal the used cable holes with sealing putty. Seal the unused cable holes with the caps delivered with the equipment. The following figure shows the criteria for correct sealing with sealing putty.

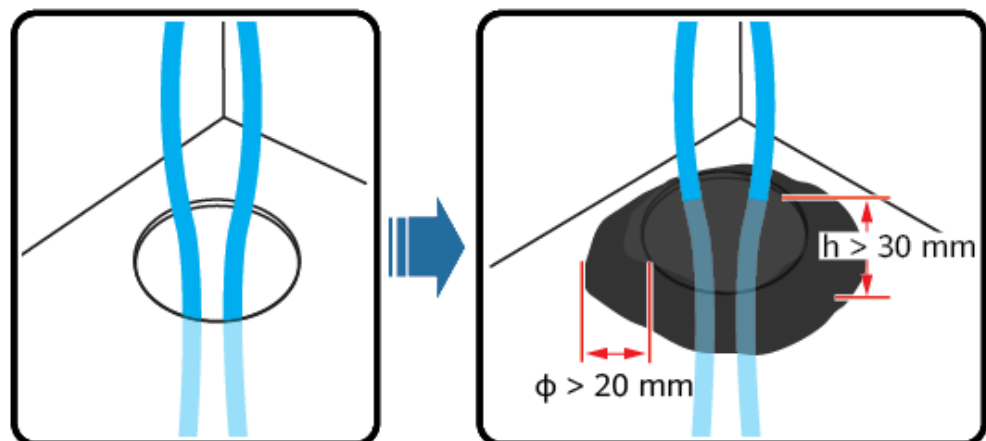

TN01H00006

- After installing the equipment, remove the packing materials such as cartons, foam, plastics, and cable ties from the equipment area.

1.4 Mechanical Safety

DANGER

When working at heights, wear a safety helmet and safety harness or waist belt and fasten it to a solid structure. Do not mount it on an insecure moveable object or metal object with sharp edges. Make sure that the hooks will not slide off.

 **WARNING**

Ensure that all necessary tools are ready and inspected by a professional organization. Do not use tools that have signs of scratches or fail to pass the inspection or whose inspection validity period has expired. Ensure that the tools are secure and not overloaded.

 **WARNING**

Before installing equipment in a cabinet, ensure that the cabinet is securely fastened with a balanced center of gravity. Otherwise, tipping or falling cabinets may cause bodily injury and equipment damage.

 **WARNING**

When pulling equipment out of a cabinet, be aware of unstable or heavy objects in the cabinet to prevent injury.

 **WARNING**

Do not drill holes into the equipment. Doing so may affect the sealing performance and electromagnetic containment of the equipment and damage components or cables inside. Metal shavings from drilling may short-circuit boards inside the equipment.

General Requirements

- Repaint any paint scratches caused during equipment transportation or installation in a timely manner. Equipment with scratches must not be exposed for an extended period of time.
- Do not perform operations such as arc welding and cutting on the equipment without evaluation by the Company.
- Do not install other devices on the top of the equipment without evaluation by the Company.
- When performing operations over the top of the equipment, take measures to protect the equipment against damage.
- Use correct tools and operate them in the correct way.

Moving Heavy Objects

- Be cautious to prevent injury when moving heavy objects.

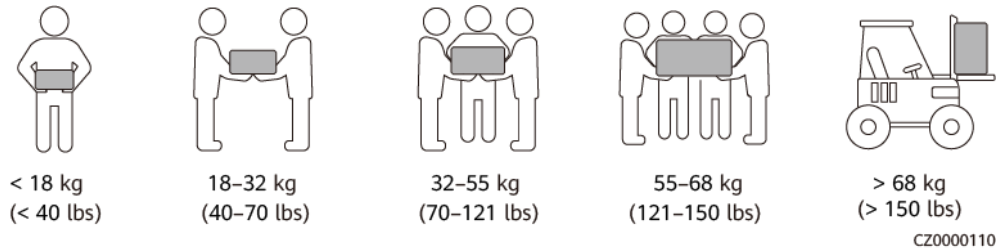

- If multiple persons need to move a heavy object together, determine the manpower and work division with consideration of height and other conditions to ensure that the weight is equally distributed.
- If two persons or more move a heavy object together, ensure that the object is lifted and landed simultaneously and moved at a uniform pace under the supervision of one person.
- Wear personal protective gears such as protective gloves and shoes when manually moving the equipment.
- To move an object by hand, approach to the object, squat down, and then lift the object gently and stably by the force of the legs instead of your back. Do not lift it suddenly or turn your body around.
- Move or lift the equipment by holding its handles or lower edges. Do not hold the handles of modules that are installed in the equipment.
- Do not quickly lift a heavy object above your waist. Place the object on a workbench that is half-waist high or any other appropriate place, adjust the positions of your palms, and then lift it.
- Move a heavy object stably with balanced force at an even and low speed. Put down the object stably and slowly to prevent any collision or drop from scratching the surface of the equipment or damaging the components and cables.
- When moving a heavy object, be aware of the workbench, slope, staircase, and slippery places. When moving a heavy object through a door, ensure that the door is wide enough to move the object and avoid bumping or injury.
- When transferring a heavy object, move your feet instead of turning your waist around. When lifting and transferring a heavy object, ensure that your feet point to the target direction of movement.
- When transporting the equipment using a pallet truck or forklift, ensure that the tynes are properly positioned so that the equipment does not topple. Before moving the equipment, secure it to the pallet truck or forklift using ropes. When moving the equipment, assign dedicated personnel to take care of it.
- Choose sea or roads in good conditions for transportation as transportation by railway or air is not supported. Avoid tilt or jolt during transportation.

Working at Heights

- Any operations performed 2 m or higher above the ground shall be supervised properly.
- Only trained and qualified personnel are allowed to work at heights.
- Do not work at heights when steel pipes are wet or other risky situations exist. After the preceding conditions no longer exist, the safety owner and

relevant technical personnel need to check the involved equipment. Operators can begin working only after safety is confirmed.

- Set a restricted area and prominent signs for working at heights to warn away irrelevant personnel.
- Set guard rails and warning signs at the edges and openings of the area involving working at heights to prevent falls.
- Do not pile up scaffolding, springboards, or other objects on the ground under the area involving working at heights. Do not allow people to stay or pass under the area involving working at heights.
- Carry operation machines and tools properly to prevent equipment damage or personal injury caused by falling objects.
- Personnel involving working at heights are not allowed to throw objects from the height to the ground, or vice versa. Objects shall be transported by slings, hanging baskets, highline trolleys, or cranes.
- Do not perform operations on the upper and lower layers at the same time. If unavoidable, install a dedicated protective shelter between the upper and lower layers or take other protective measures. Do not pile up tools or materials on the upper layer.
- Dismantle the scaffolding from top down after finishing the job. Do not dismantle the upper and lower layers at the same time. When removing a part, ensure that other parts will not collapse.
- Ensure that personnel working at heights strictly comply with the safety regulations. The Company is not responsible for any accident caused by violation of the safety regulations on working at heights.
- Behave cautiously when working at heights. Do not rest at heights.

Using Ladders

- Use wooden or insulated ladders when you need to perform live-line working at heights.
- Platform ladders with protective rails are preferred. Do not use single ladders.
- Before using a ladder, check that it is intact and confirm its load bearing capacity. Do not overload it.
- Ensure that the ladder is securely positioned and held firm.



CZ00000107

- When climbing up the ladder, keep your body stable and your center of gravity between the side rails, and do not overreach to the sides.
- When a step ladder is used, ensure that the pull ropes are secured.

Hoisting

- Only trained and qualified personnel are allowed to perform hoisting operations.
- Install temporary warning signs or fences to isolate the hoisting area.
- Ensure that the foundation where hoisting is performed on meets the load-bearing requirements.
- Before hoisting objects, ensure that hoisting tools are firmly secured onto a fixed object or wall that meets the load-bearing requirements.
- During hoisting, do not stand or walk under the crane or the hoisted objects.
- Do not drag steel ropes and hoisting tools or bump the hoisted objects against hard objects during hoisting.
- Ensure that the angle between two hoisting ropes is no more than 90 degrees, as shown in the following figure.

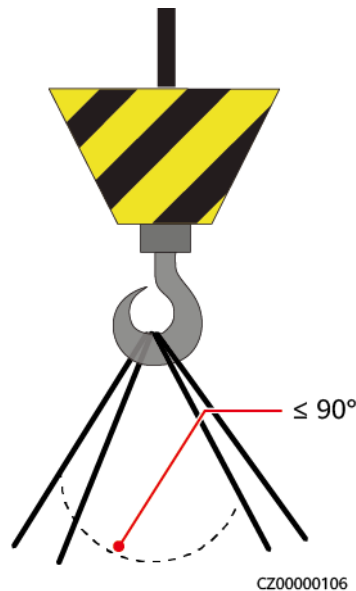

Drilling Holes

- Obtain consent from the customer and contractor before drilling holes.
- Wear protective equipment such as safety goggles and protective gloves when drilling holes.
- To avoid short circuits or other risks, do not drill holes into buried pipes or cables.
- When drilling holes, protect the equipment from shavings. After drilling, clean up any shavings.

1.5 Equipment Safety

1.5.1 ESS Safety

 **DANGER**

Do not open cabinet doors when the system is running.

 **DANGER**

If the ESS is faulty, do not stand within the opening range of the cabinet doors.

 **CAUTION**

Evacuate from the site immediately once the fire alarm horn/strobe is triggered.

NOTICE

Take protection and isolation measures for the ESS, such as installing fences, walls, and safety warning signs to prevent personal injury or property damage caused by unauthorized access during operations.

- When installing the ESS, comply with the fire separation distance or fire wall requirements specified in local standards, including but not limited to *GB 51048-2014 Design Code for Electrochemical Energy Storage Station* and *NFPA 855 Standard for the Installation of Stationary Energy Storage Systems*.
- Check the fire safety of the ESS regularly, at least once a month.
- When inspecting the system with power on, pay attention to the hazard warning signs on the equipment. Do not stand at the battery cabin doors.
- After power components of the ESS are replaced or cable connections are changed, you need to manually start cable connection detection and topology identification to prevent system malfunction.
- It is recommended that you prepare a camera to record the detailed processes of equipment installation, operation, and maintenance.

1.5.2 Battery Safety

 **DANGER**

Do not connect the positive and negative poles of a battery together. Otherwise, the battery may be short-circuited. Battery short circuits can generate high instantaneous current and releases a large amount of energy, which may cause battery leakage, smoke, flammable gas release, thermal runaway, fire, or explosion. To avoid battery short circuits, do not maintain batteries with power on.

 **DANGER**

Do not expose batteries at high temperatures or around heat sources, such as scorching sunlight, fire sources, transformers, and heaters. Battery overheating may cause leakage, smoke, flammable gas release, thermal runaway, fire, or explosion.

 **DANGER**

Protect batteries from mechanical vibration, falling, collision, punctures, and strong impact. Otherwise, the batteries may be damaged or catch fire.

 **DANGER**

To avoid leakage, smoke, flammable gas release, thermal runaway, fire, or explosion, do not disassemble, alter, or damage batteries, for example, insert foreign objects into batteries, squeeze batteries, or immerse batteries in water or other liquids.

 **DANGER**

Do not touch battery terminals with other metal objects, which may cause heat or electrolyte leakage.

 **DANGER**

There is a risk of fire or explosion if the model of the battery in use or used for replacement is incorrect. Use a battery of the model recommended by the manufacturer.

 **DANGER**

Battery electrolyte is toxic and volatile. Do not get contact with leaked liquids or inhale gases in the case of battery leakage or odor. In such cases, stay away from the battery and contact professionals immediately. Professionals must wear safety goggles, rubber gloves, gas masks, and protective clothing, power off the equipment, remove the battery, and contact technical engineers.

 **DANGER**

A battery is an enclosed system and will not release any gases under normal operations. If a battery is improperly treated, for example, burnt, needle-pricked, squeezed, struck by lightning, overcharged, or subject to other adverse conditions that may cause battery thermal runaway, the battery may be damaged or an abnormal chemical reaction may occur inside the battery, resulting in electrolyte leakage or production of gases such as CO and H₂. To prevent fire or device corrosion, ensure that flammable gas is properly exhausted.

 **DANGER**

The gas generated by a burning battery may irritate your eyes, skin, and throat. Take protective measures promptly.

 **WARNING**

Install batteries in a dry area. Do not install them under areas prone to water leakage, such as air conditioner vents, ventilation vents, feeder windows of the equipment room, or water pipes. Ensure that no liquid enters the equipment to prevent faults or short circuits.

 **WARNING**

Before installing and commissioning batteries, prepare fire fighting facilities, such as fire sand and carbon dioxide fire extinguishers, according to construction standards and regulations. Before putting into operation, ensure that fire fighting facilities that comply with local laws and regulations are installed.

 **WARNING**

Before unpacking, storage, and transportation, ensure that the packing cases are intact and the batteries are correctly placed according to the labels on the packing cases. Do not place a battery upside down or vertically, lay it on one side, or tilt it. Stack the batteries according to the stacking requirements on the packing cases. Ensure that the batteries do not fall or get damaged. Otherwise, they will need to be scrapped.

 **WARNING**

After unpacking batteries, place them in the required direction. Do not place a battery upside down or vertically, lay it on one side, tilt it, or stack it. Ensure that the batteries do not fall or get damaged. Otherwise, they will need to be scrapped.

 **WARNING**

Tighten the screws on copper bars or cables to the torque specified in this document. Periodically confirm whether the screws are tightened, check for rust, corrosion, or other foreign objects, and clean them up if any. Loose screw connections will result in excessive voltage drops and batteries may catch fire when the current is high.

 **WARNING**

After batteries are discharged, charge them in time to avoid damage due to overdischarge.

Statement

The Company shall not be liable for any damage or other consequences to the batteries it provides due to the following reasons:

- Batteries are damaged due to force majeure such as earthquakes, floods, volcanic eruptions, debris flows, lightning strikes, fires, wars, armed conflicts, typhoons, hurricanes, tornadoes, and other extreme weather conditions.
- Batteries are damaged because the onsite equipment operating environment or external power parameters do not meet the environment requirements for normal operation, for example, the actual operating temperature of batteries is too high or too low, or the power grid is unstable and experiences outages frequently.
- Batteries are damaged, fall, leak, or crack due to improper operations or incorrect connection.
- After being installed and connected to the system, the batteries are not powered on in time due to your reasons, which causes damage to the batteries due to overdischarge.
- Batteries are damaged because they are not accepted in time due to your reasons.
- You set battery operating parameters incorrectly.
- You use batteries of different types together, causing acceleration of capacity attenuation. For example, you use our batteries together with batteries of other vendors or with batteries of different rated capacity.
- You maintain batteries improperly, causing frequent overdischarge; you expand the load capacity without notifying us; or you have not fully charged the batteries for a long time.
- You do not perform battery maintenance based on the operation guide, such as failure to check battery terminals regularly.
- Batteries are damaged because you do not store them in accordance with storage requirements (for example, in an environment that is damp or prone to rain).
- Batteries are not charged as required during storage due to your reasons, resulting in capacity loss or other irreversible damages to the batteries.

- Batteries are damaged due to your or a third party's reasons, for example, relocating or reinstalling the batteries without complying with the Company's requirements.
- You change the battery use scenarios without notifying the Company.
- You connect extra loads to the batteries.
- The battery storage period has exceeded the upper limit.
- The battery warranty period has expired. You are advised not to use a battery whose warranty period has expired, as this poses safety risks.

General Requirements

NOTICE

To ensure battery safety and battery management accuracy, use batteries provided by the Company. The Company is not responsible for any faults of batteries not provided by it.

- Before installing, operating, and maintaining batteries, read the battery manufacturer's instructions and comply with their requirements. The safety precautions specified in this document are highly important and require special attention. For additional safety precautions, see the instructions provided by the battery manufacturer.
- Use batteries within the specified temperature range. When the ambient temperature of the batteries is lower than the allowed range, do not charge the batteries to prevent internal short circuits caused during low-temperature charging.
- Before unpacking batteries, check whether the packaging is intact. Do not use batteries with damaged packaging. If any damage is found, notify the carrier and manufacturer immediately.
- Install batteries within 24 hours after unpacking. If the batteries cannot be installed in time, put them in the original packaging and place them in a dry indoor environment without corrosive gases. Power on the ESS within 24 hours after installation. The process from unpacking batteries to powering on the system must be completed within 72 hours. During routine maintenance, ensure that the power-off time does not exceed 24 hours.
- Do not use a damaged battery (such as damage caused when a battery is dropped, bumped, bulged, or dented on the enclosure), because the damage may cause electrolyte leakage or flammable gas release. In the case of electrolyte leakage or structural deformation, contact the installer or professional O&M personnel immediately to remove or replace the battery. Do not store the damaged battery near other devices or flammable materials and keep it away from non-professionals.
- Before working on a battery, ensure that there is no irritant or scorched smell around the battery.
- When installing batteries, do not place installation tools, metal parts, or sundries on the batteries. After the installation is complete, clean up the objects on the batteries and the surrounding area.

- Do not install battery packs on rainy, snowy, or foggy days. Otherwise, the battery packs may be corroded by moisture or rain.
- If batteries are exposed to water accidentally, do not install them. Instead, transport the batteries to a safe isolation point and dispose of them in a timely manner.
- Before installing battery packs, check whether they are abnormal. A battery pack is deemed abnormal when any of the following symptoms occurs:
 - The enclosure of the battery pack is obviously deformed or damaged.
 - The voltage between the positive and negative electrodes of the battery pack is far below the specified range.
- Check whether the positive and negative battery terminals are grounded unexpectedly. If so, disconnect the battery terminals from the ground.
- Do not perform welding or grinding work around batteries to prevent fire caused by electric sparks or arcs.
- If batteries are left unused for a long period of time, store and charge them according to the battery requirements.
- Do not charge or discharge batteries by using a device that does not comply with local laws and regulations.
- Keep the battery loop disconnected during installation and maintenance.
- Monitor damaged batteries during storage for signs of smoke, flame, electrolyte leakage, or heat.
- If a battery is faulty, its surface temperature may be high. Do not touch the battery to avoid scalds.
- Do not stand on, lean on, or sit on the top of the equipment.
- In backup power scenarios, do not use the batteries for the following situations:
 - Medical devices substantially important to human life
 - Control equipment such as trains and elevators, as this may cause personal injury
 - Computer systems of social and public importance
 - Locations near medical devices
 - Other devices similar to those described above

Short-Circuit Protection

- When installing and maintaining batteries, wrap the exposed cable terminals on the batteries with insulation tape.
- Avoid foreign objects (such as conductive objects, screws, and liquids) from entering a battery, as this may cause short circuits.

Leakage Handling

NOTICE

Electrolyte leakage may damage the equipment. It will corrode metal parts and boards, and ultimately damage the boards.

Electrolyte is corrosive and can cause irritation and chemical burns. If you come into direct contact with the battery electrolyte, do as follows:

- Inhalation: Evacuate from contaminated areas, get fresh air immediately, and seek immediate medical attention.
- Eye contact: Immediately wash your eyes with water for at least 15 minutes, do not rub your eyes, and seek immediate medical attention.
- Skin contact: Wash the affected areas immediately with soap and water and seek immediate medical attention.
- Intake: Seek immediate medical attention.

Recycling

- Dispose of waste batteries in accordance with local laws and regulations. Do not dispose of batteries as household waste. Improper disposal of batteries may result in environmental pollution or an explosion.
- If a battery leaks or is damaged, contact technical support or a battery recycling company for disposal.
- If batteries are out of service life, contact a battery recycling company for disposal.
- Do not expose waste batteries to high temperatures or direct sunlight.
- Do not place waste batteries in environments with high humidity or corrosive substances.
- Do not use faulty batteries. Contact a battery recycling company to scrap them as soon as possible to avoid environmental pollution.

2 Routine Maintenance

⚠ CAUTION





Safety requirements in maintenance and repair:





- Before connecting or removing cables, turn off the protection switch of the corresponding loop.
- Place a warning sign indicating that the switch must not be turned on at the position where the switch resides.
- Use an electroscope of a proper voltage level to check whether the equipment is energized and ensure that the equipment is completely powered off.
- If charged bodies are found nearby, block or wrap them with insulation plates or insulation tapes.
- Before performing maintenance or repair, securely connect the loop to be repaired to the main ground loop using a ground cable.
- After the maintenance or repair is complete, remove the ground cable between the loop that has been maintained and the main ground loop.

2.1 Preparations Before Maintenance

📖 NOTE

This section lists only personal protective equipment (PPE). For details about the tools required for replacement, see the specific parts replacement section.

			
Insulated gloves	Protective gloves	Goggles	Dust mask

 <p>Insulated shoes</p>	 <p>Reflective vest</p>	 <p>Safety helmet</p>	 <p>Safety harness</p>
 <p>Medical kit</p>	-	-	-

2.2 Powering Off a Single ESS

2.2.1 Sending a Shutdown Command on the SmartLogger



Step 1 Log in to the SmartLogger WebUI, choose **Overview** > , and click  to send a batch shutdown command to the ESSs connected to the same DC bus.

Figure 2-1 Batch shutdown of the ESSs connected to the same DC bus



Step 2 Click **Monitoring** and check that the indicators for the PCS, ESC, and ESR are yellow or gray.

----End

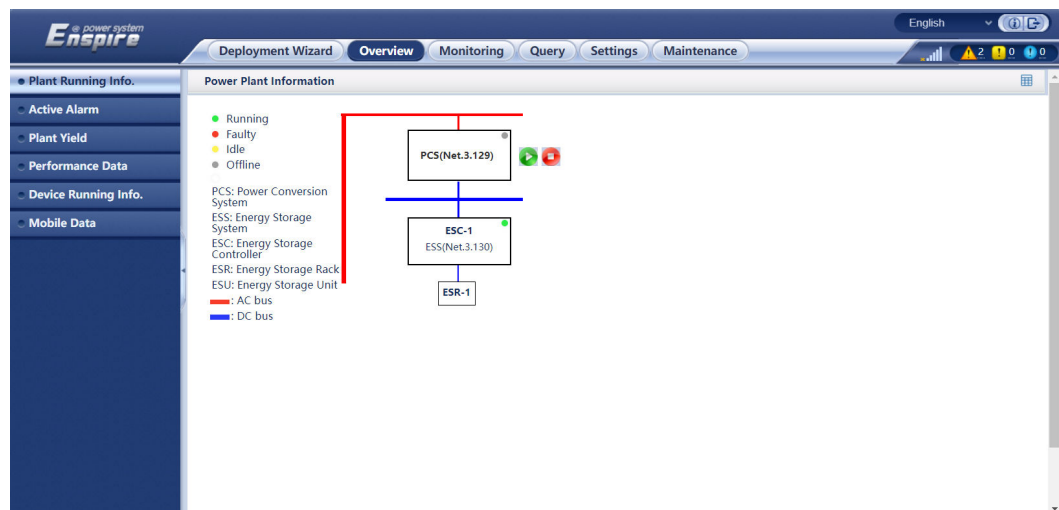
2.2.2 Power-Off Process

Table 2-1 Power-off procedure

Step	Item	Remarks
1	Powering off the AC side of the Smart PCS	Powering off the battery side of the AC power distribution cabinet As shown by (1) in Figure 2-2 .
2	Powering off the ESS	Powering off the output DC circuit breakers As shown by (2) in Figure 2-2 .
3		Powering off the auxiliary power supply (turn off the AC switches and then the DC switches) As shown by (3) in Figure 2-2 .
4		Powering off the DC circuit breakers of battery racks As shown by (4) in Figure 2-2 .
5	Powering off the auxiliary power supply	Powering off the 220 V AC auxiliary power supply As shown by (5) in Figure 2-2 .
6		(Optional) Powering off the UPS As shown by (6) and (7) in Figure 2-2 .

Figure 2-2 Power-off process

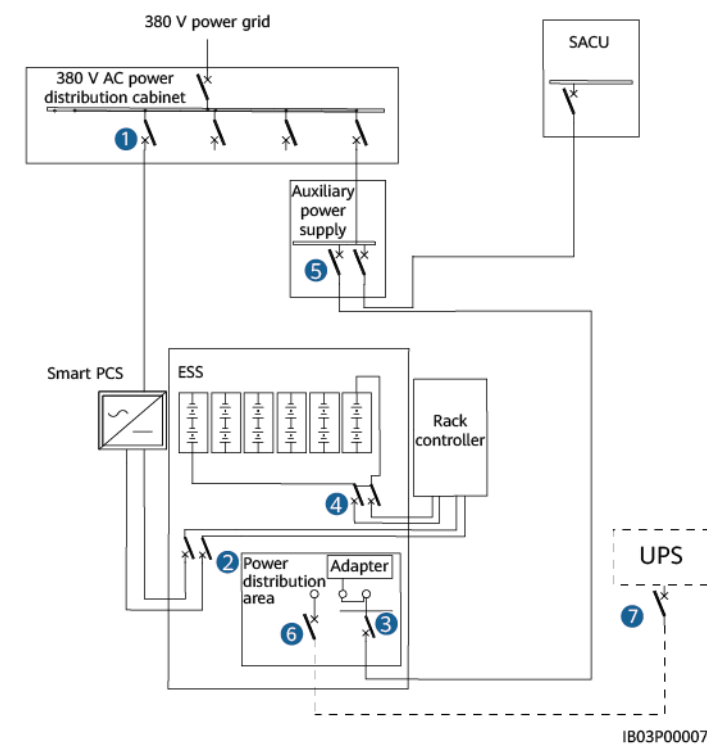

2.2.3 Power-Off Operations

Step 1 Turn off all switches in the power distribution system of the ESS.

1. On the embedded power subrack (SK1), turn off the DC/DC switch 2FCB1, DC light power switch 2FCB2, TCUE switch 2FCB3, fan 1 switch 2FCB6, fan 2 switch 2FCB7, air conditioner 1 switch 2FCB8, and air conditioner 2 switch 2FCB9 in sequence.
2. (Optional) Turn off the 220 V maintenance socket switch 1FB1.
3. Turn off the PSU switch 1FCB2.
4. Turn off the 12 V adapter switch 1FCB1.

Step 2 Turn off the AC main switch 1FCB.

Step 3 (Optional) Turn off the UPS cable inlet switch 5FCB.

Step 4 Turn off the DC switch 1Q1.

Step 5 Turn off the switch between the AC side of the ESS and the power grid.

----End

2.2.4 Powering Off the Power Supply Loop of the AC Power Distribution Cabinet

Step 1 Turn off the switches between the AC power distribution cabinet and the ESS.

----End

2.3 Routine Maintenance

2.3.1 Unscheduled Maintenance

Log in to the SmartLogger WebUI/CMU WebUI/FusionSolar app/SmartPVMS and check whether there are major or minor alarms.

 **NOTE**

For details, see the software user manuals.

2.3.2 Quarterly Maintenance

Table 2-2 Quarterly maintenance checklist

Maintenance Category	Maintenance Action	Expected Result	System Powered Off or Not
Cabinet	Perform the visual inspection: <ul style="list-style-type: none"> Appearance Rust condition Door lock Vent 	<ul style="list-style-type: none"> The coating is not peeling or scratched. There is no obvious paint peeling or rust. The door locks are not damaged. There is no dust at the vents. There are no insects, rodents, snakes or other animals. 	No
Air conditioner [1]	<ul style="list-style-type: none"> Check the appearance. Clean the filter^[2]. 	<ul style="list-style-type: none"> There is no obvious damage to the appearance. There is no obvious paint peeling or rust. The screws are secured. The fans rotate properly without abnormal sound. The filter is clean and free from blockage. 	No
Adapter	Check the indicator status.	The indicator is steady green.	No
Power distribution area	Check whether there are foreign objects in the power distribution area.	The area is clean and free from foreign objects.	No
Pressure relief window ^[3]	Perform the visual inspection: <ul style="list-style-type: none"> Appearance Rust condition Foreign objects/Ice and snow 	<ul style="list-style-type: none"> There is no obvious paint peeling or rust. Pressure relief windows are not damaged. There is no foreign object, ice, or snow on the top. 	No

Maintenance Category	Maintenance Action	Expected Result	System Powered Off or Not
<p>Note [1]: Monthly maintenance is recommended in a high-temperature ($\geq 35^{\circ}\text{C}$) or low-temperature ($\leq 0^{\circ}\text{C}$) environment.</p> <p>Note [2]: You are advised to clean the filter after each occurrence of a sandstorm and before summer in sandstorm-stricken areas. In other areas, clean the filter according to the actual situation and ensure that the filter or condenser is not blocked. The recommended tool is high pressure water gun.</p> <p>Note [3]: In areas with severe sandstorms or heavy ice or snow, perform maintenance based on the actual situation. Ensure that there is no foreign object, ice, or snow on the pressure relief windows. Clean the foreign objects, ice, or snow in the specified area to avoid damaging the pressure relief devices due to improper operations.</p>			

2.3.3 Semi-annual Maintenance

Table 2-3 Semi-annual maintenance checklist

Maintenance Category	Maintenance Action	Expected Result	System Powered Off or Not
Air conditioner	Perform the visual inspection: <ul style="list-style-type: none"> • Appearance • Rust condition • Screw • Fan • Filter 	<ul style="list-style-type: none"> • There is no obvious damage to the appearance. • There is no obvious paint peeling or rust. • The screws are secured. • The fans rotate properly without abnormal sound. • The filter is clean and free from blockage. 	No
Air conditioner external fan	Clean the air filter of the external fan ^[1] .	The filter is clean and free from blockage.	No
Smoke detector and temperature and humidity (T/H) sensor	Spot check the smoke detector and T/H sensor with smoke or heat generated by using dedicated devices ^[2] .	The smoke detector indicator is steady red, and the T/H sensor reports the temperature change on the CMU.	Yes

Maintenance Category	Maintenance Action	Expected Result	System Powered Off or Not
Fire suppression module	<ul style="list-style-type: none"> Check whether the pressure gauge pointer of the module is in the green area. Clean the module. Check that cables are not damaged, loose, or disconnected. 	<ul style="list-style-type: none"> The display is normal. The module is clean and free from dust. Cables are intact and securely connected. 	Yes
<p>Note [1]: You are advised to clean the filter after each occurrence of a sandstorm and before summer in sandstorm-stricken areas. In other areas, clean the filter according to the actual situation and ensure that the filter or condenser is not blocked. The recommended tool is high pressure water gun.</p> <p>Note [2]: Remove cables from the solenoid valve in advance of the test to prevent extinguishant release.</p>			

2.3.4 Annual Maintenance

Table 2-4 Annual maintenance checklist

Maintenance Category	Maintenance Action	Expected Result	System Powered Off or Not
Battery pack	Perform the visual inspection: <ul style="list-style-type: none"> Appearance Rust condition Screw Fan Front panel vent 	<ul style="list-style-type: none"> There is no obvious damage to the appearance. There is no obvious paint peeling or rust. The screws are secured. The fans rotate properly without abnormal sound. The front panel vent is clean and free from blockage. 	Yes
Adapter	Check the indicator status.	The indicator is steady green.	No

3 Alarm Reference

For details about alarms, see the [LUNA2000-200KWH Series Smart String ESS Alarm Reference](#).

4 Replacing a Battery Pack

Context

NOTE

The Company is responsible for maintaining and transferring abnormal battery packs within the warranty scope. For a battery pack whose warranty period has expired, contact the local recycling agencies for handling.

Prerequisites

- Fault locating:
 - a. Log in to the SmartLogger WebUI, CMU WebUI, FusionSolar app, or management system to view alarm information.
 - b. Locate the faulty battery pack based on the alarm information.
 - c. Refer to the alarm handling suggestions in the alarm list.
- Tools: insulated torque socket wrench (including an extension bar), battery installation tray kit (installation kit for short), infrared thermometer
- Power off the ESS. For details, see [2.2 Powering Off a Single ESS](#).
- At least four persons are required to replace the component.

DANGER

- Before replacing a battery pack, ensure that the ESS is powered off. Otherwise, electric shocks may occur.
 - Wear personal protective equipment and use dedicated insulated tools to avoid electric shocks or short circuits.
 - Do not smoke or have an open flame around batteries.
 - Do not use wet cloth to clean exposed copper bars or other conductive parts.
 - Do not use water or any solvent to clean batteries.
-

 **WARNING**

Do not maintain batteries with power on. To power off the batteries before performing operations such as checking and tightening screw torques, explain the risks to the customer, obtain the customer's written consent, and take effective preventive measures.

 **CAUTION**

Exercise caution when moving batteries to prevent bumping and ensure personal safety.

NOTICE

- Before installation, ensure that battery packs are stored indoors and that other storage requirements specified in the user manual are met.
 - Before installation, check the status of the battery packs. Do not use the battery packs if the packing cases are exposed to rain, damaged, or deformed, or if the battery packs leak or fall.
 - Install batteries within 24 hours after unpacking. If the batteries cannot be installed in time, put them in the original packaging and place them in a dry indoor environment without corrosive gases. Power on the ESS within 24 hours after installation. The process from unpacking batteries to powering on the system must be completed within 72 hours. During routine maintenance, ensure that the power-off time does not exceed 24 hours.
 - Do not install battery packs on rainy, snowy, or foggy days. Otherwise, the battery packs may be corroded by moisture or rain.
-

Procedure

Step 1 Check the battery pack status.

1. Ensure that the indicator on the front panel of the battery pack is off.
2. Check the temperature of the copper bars and screws of the battery pack using an infrared thermometer. If the temperature is too high, wait until the battery pack cools down before proceeding to the next step.
3. If any irritating odor, leakage, bulging, or damage is present, contact service engineers for handling.
4. If sparks or burn marks occur on the front panel or handles of the battery pack, contact service engineers for handling.
5. If the battery pack appears normal and without irritating odor, remove the faulty battery pack.

Step 2 Press to open the covers on both sides of the battery pack.

Figure 4-1 Opening the battery pack covers

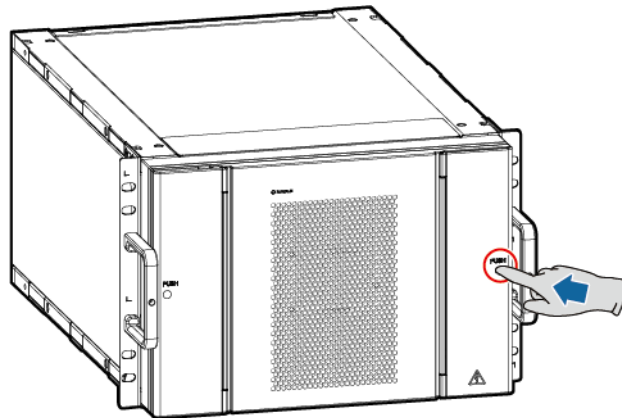

IB04H00010

Step 3 Remove copper bars and cables from the battery pack, and close the cover.

Figure 4-2 Removing copper bars and cables

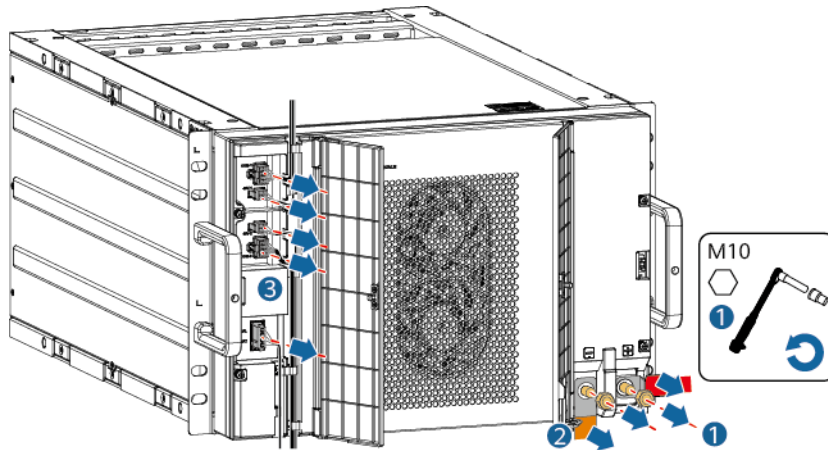

IB04H00052

Step 4 Remove screws from the battery pack.

Figure 4-3 Removing screws

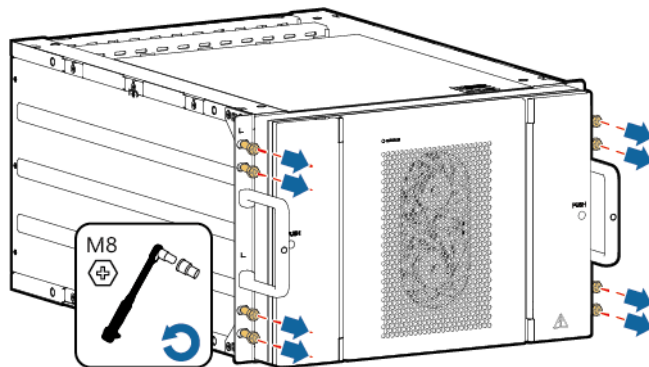

IB04H00021

Step 5 Use a forklift to transport the installation kit to the vicinity of the ESS.

Figure 4-4 Forklift space dimensions

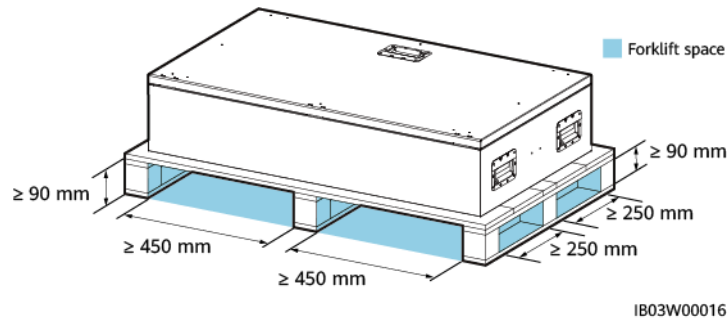

Step 6 Take out the installation kit.

Figure 4-5 Taking out the installation kit

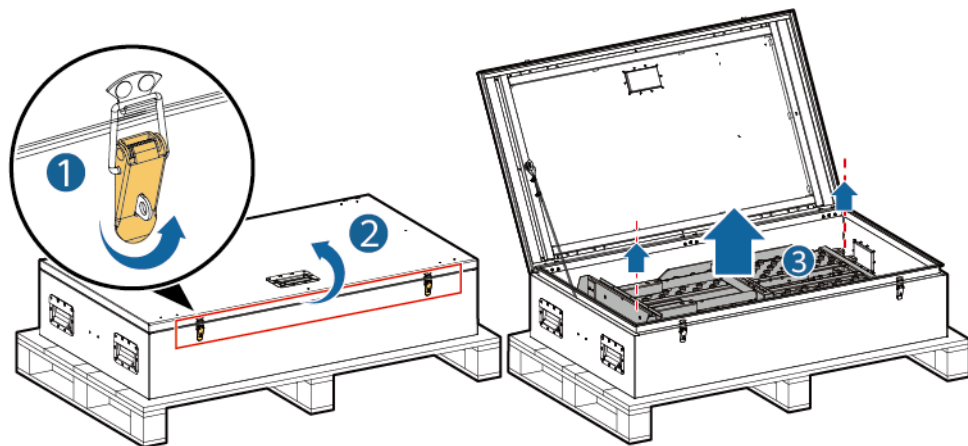

Step 7 Insert, assemble, and secure the installation kit onto the forklift.

Figure 4-6 Assembling the installation kit

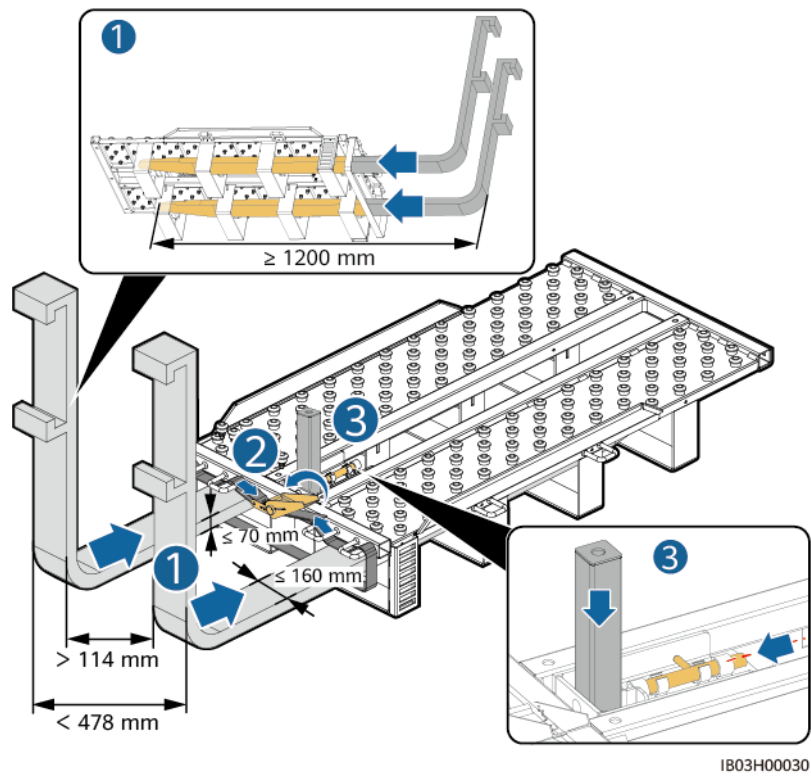

Step 8 Install the operating handle on the battery pack, pull the old battery pack onto the installation kit, and secure the battery pack.

Figure 4-7 Securing the battery pack

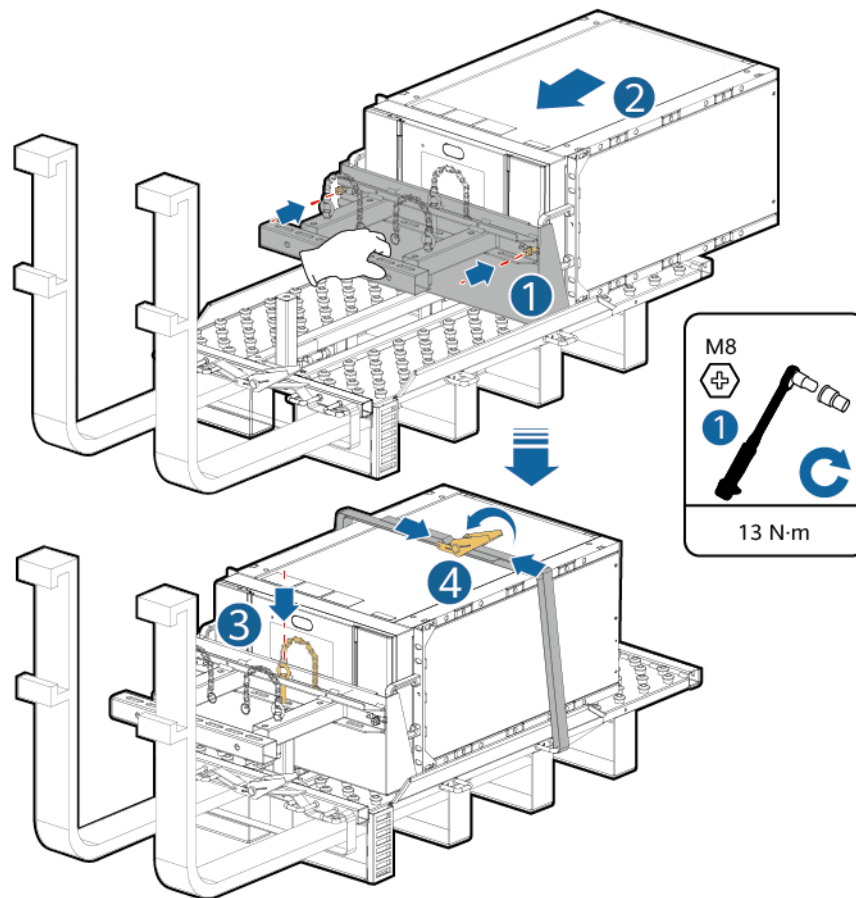

IB03H00023

Step 9 Use a forklift to put down the installation kit, remove the binding straps from the old battery pack, remove the positioning pins, install the lifting handles, and remove the old battery pack.

NOTE

- At least four persons are required to move a battery pack.
- Secure the lifting handles (with the steel washers of the lifting handles closely fitted to the battery pack).
- If the stud of a lifting handle is bent, replace the lifting handle in time.
- When using the lifting handles delivered with the product, hold the end closer to the device.

Figure 4-8 Correct and incorrect lifting handle installation

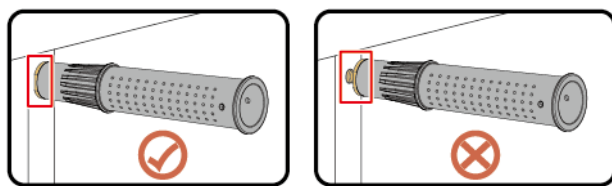

S000004

Step 10 Move the new battery pack onto the installation kit, and bind the battery pack.

Figure 4-9 Moving the new battery onto the installation kit

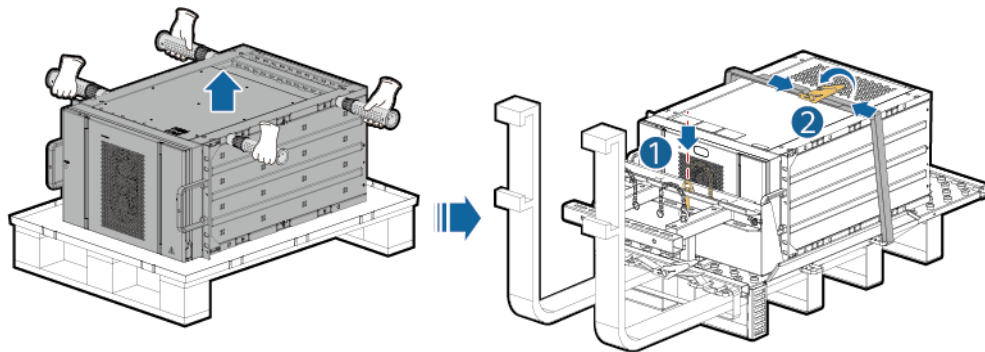

Step 11 Install the new battery pack in the ESS.

Figure 4-10 Installing the battery pack in the ESS

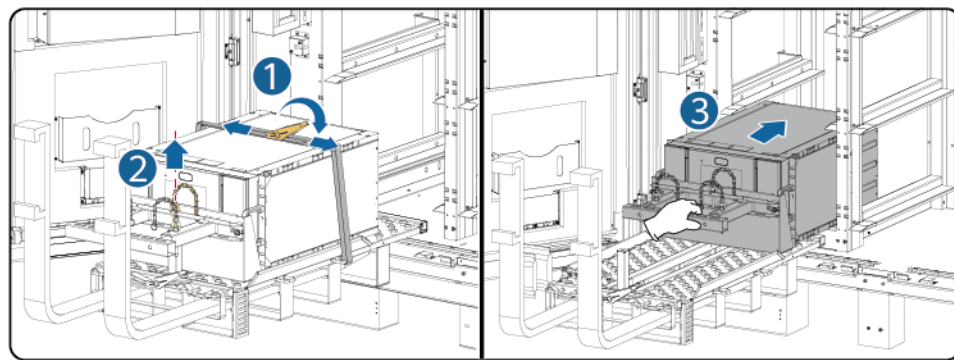

IB03H00025

Step 12 Secure the new battery pack.

Figure 4-11 Securing the battery pack

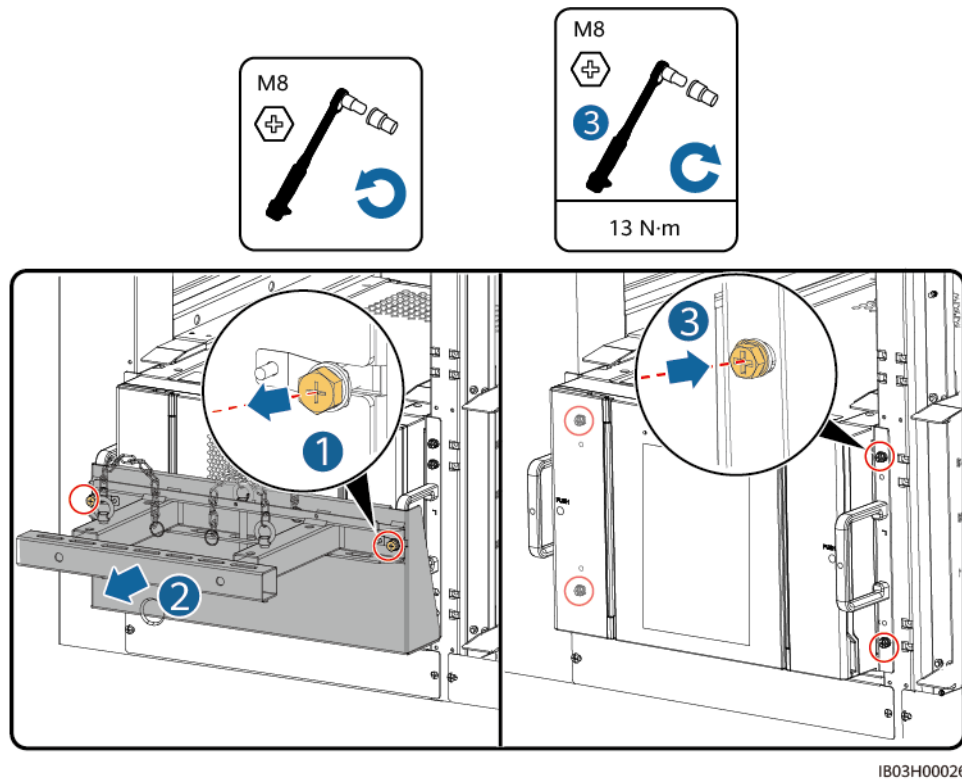

IB03H00026

Step 13 Connect cables and copper bars.

----End

Follow-up Procedure

Step 1 Power on the system. For details, see the power-on section in the ESS user manual.

Step 2 Check whether the functions are restored.

Check Item	Criteria
Alarm information	No major or minor component alarms are generated.
Function	The communication and charging/discharging functions are normal.
Running data	<ul style="list-style-type: none"> Number of modules: 12 Module voltage range: 43.2–58 V Cell voltage range: 2.5–3.65 V Module temperature range: –20°C to +55°C Charging cutoff SOC for the ESR: Set it to 90% first, and then adjust it to 100% after the system balancing is complete.

Check Item	Criteria
Appearance	<ul style="list-style-type: none">• There is no obvious damage to the appearance.• There is no obvious paint peeling or rust.• The screws are secured.• The fans rotate properly without abnormal sound.• The front panel vent is clean and free from blockage.

----End

5 Replacing a Battery Management Module

Prerequisites

- Fault locating:
 - a. Log in to the SmartLogger WebUI, CMU WebUI, FusionSolar app, or management system to view alarm information.
 - b. Refer to the alarm handling suggestions in the alarm list.
- Tools: Phillips insulated torque screwdriver, insulated torque socket wrench (including an extension bar longer than 40 mm), insulation tape, insulated gloves
- Power off the ESS. For details, see [2.2 Powering Off a Single ESS](#).
- At least four persons are required to replace the component.

Procedure

NOTE

There are multiple battery pack appearances. This section uses one type of battery pack as an example. The actual product may vary.

- Step 1** Press to open the covers on both sides of the battery pack.

Figure 5-1 Opening the battery pack covers

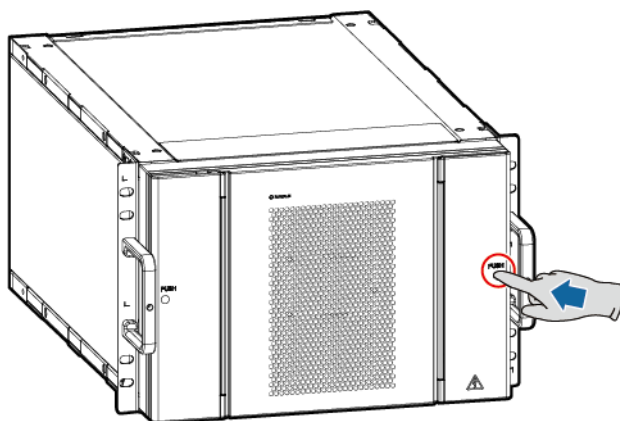

IB04H00010

Step 2 Remove copper bars and cables from the battery pack.

Figure 5-2 Removing copper bars and cables

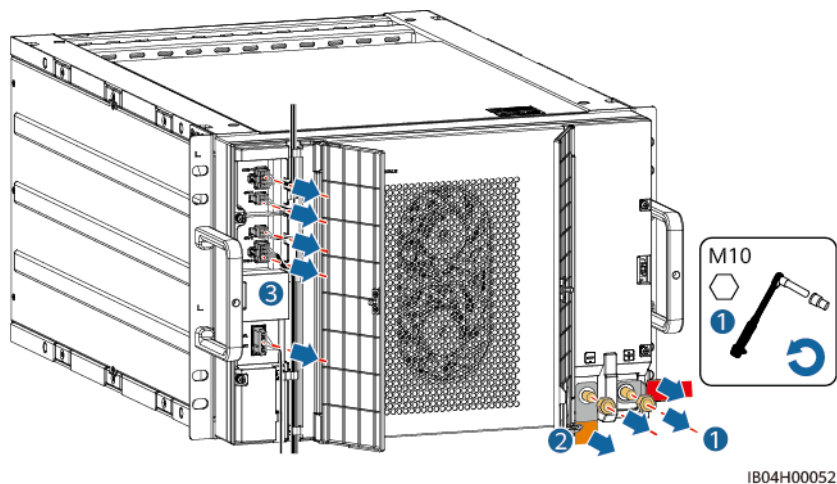

Step 3 Remove the front panel of the battery pack.

Figure 5-3 Removing the front panel of the battery pack

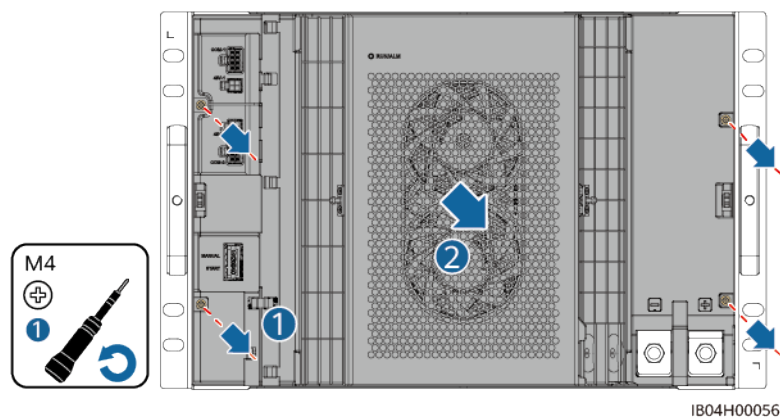

Step 4 Remove the three flat cables from the management module and wrap them with insulation tape.

Figure 5-4 Removing the flat cables

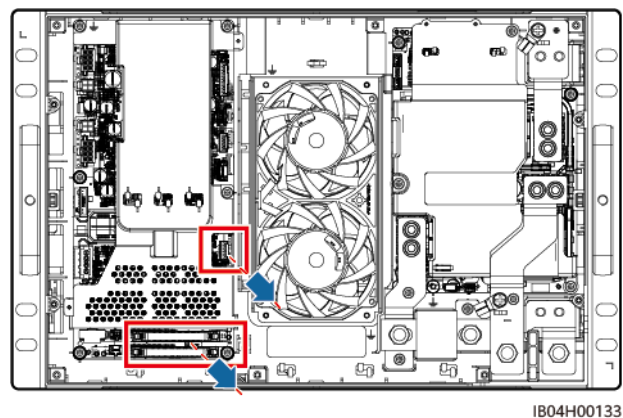

Step 5 Cut off the cable ties and install the battery pack fixture.

Figure 5-5 Installing the battery pack fixture

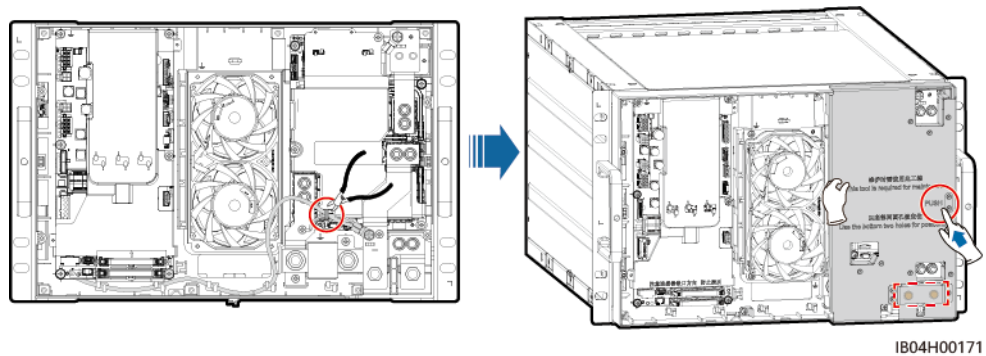

Step 6 Remove the nuts from the management module.

CAUTION

- If you do not perform operations as required, the module may be energized during maintenance, which poses safety risks.
- Use an insulated socket wrench with an extension bar longer than 40 mm.

Figure 5-6 Removing the nuts

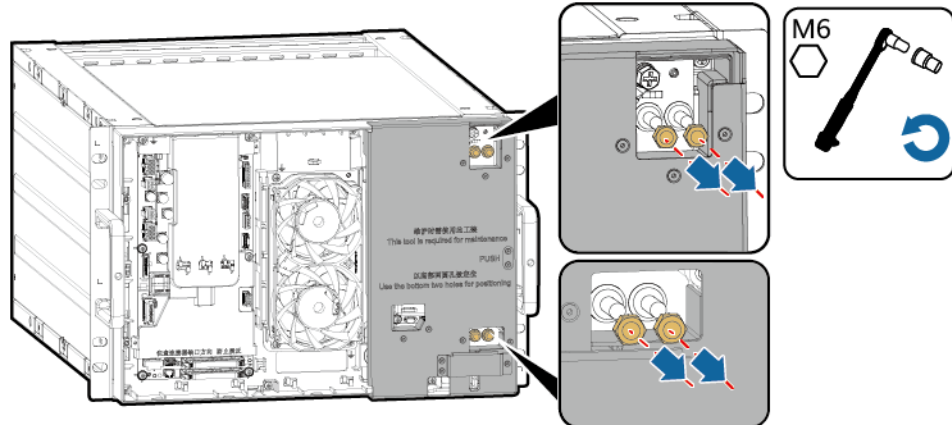

Step 7 Remove the 10 screws from the management module and remove the management module (including the battery pack fixture).

NOTICE

During the operation, prevent screws from falling into the bottom of the ESS.

Figure 5-7 Removing the screws

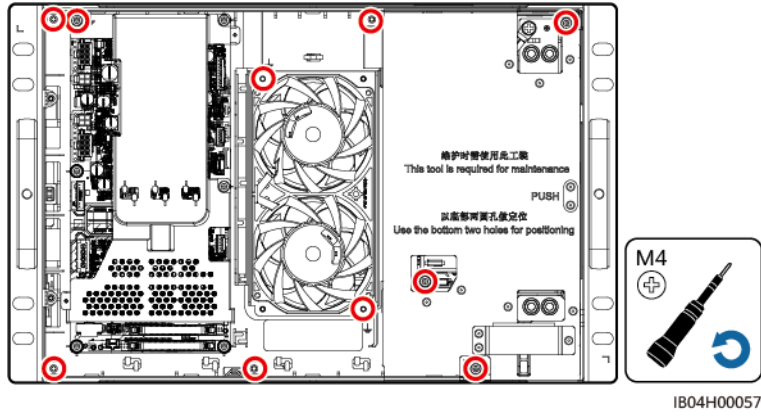

Step 8 Install a new management module.

Figure 5-8 Installing the screws

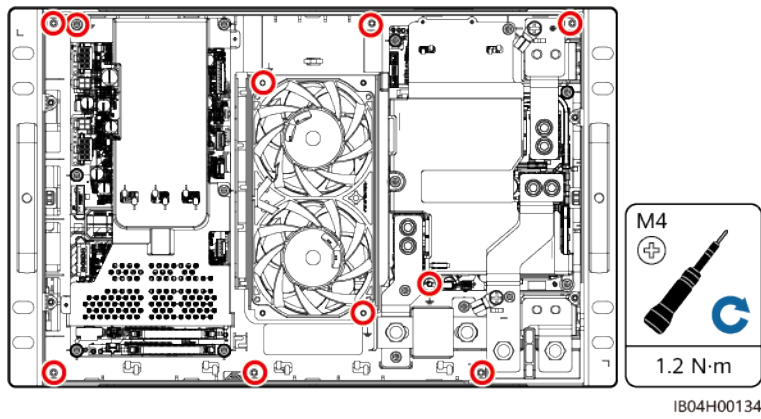

Figure 5-9 Installing the nuts

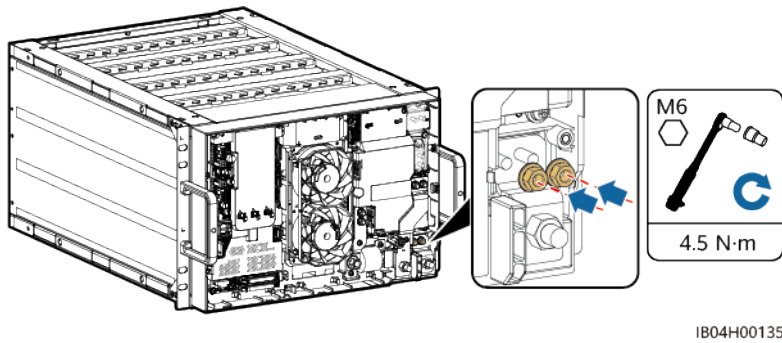
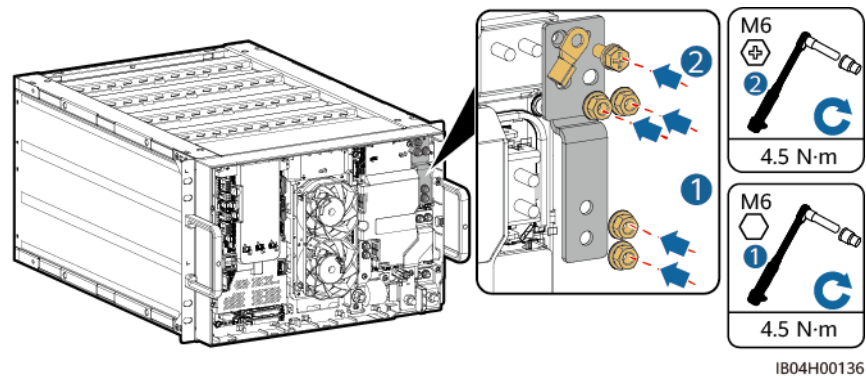
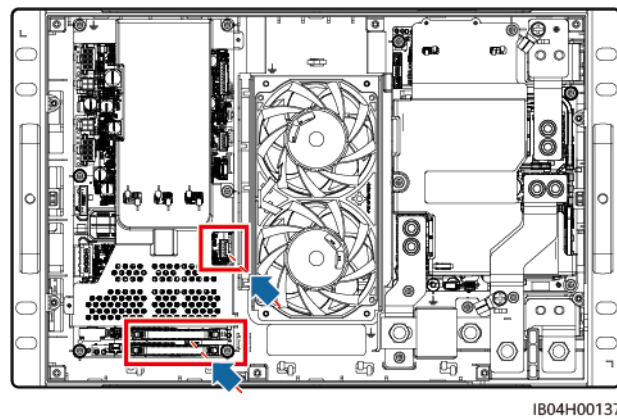

Figure 5-10 Installing the short copper bar



Step 9 Remove the insulation tape from the flat cables and install the flat cables to the management module.

Figure 5-11 Installing the flat cables



Step 10 Install the front panel. Use an M4 Phillips insulated torque screwdriver with a torque of 0.6 N·m.

Step 11 Install copper bars and cables for the battery pack.

⚠ DANGER

Note the polarities when installing batteries. Do not connect the positive and negative poles of a battery or battery string together. Otherwise, the battery may be short-circuited.

NOTICE

After installing nuts, verify the torque. Mark the nuts whose torque has been verified using a marker.

Figure 5-12 Installing copper bars and cables for the battery pack

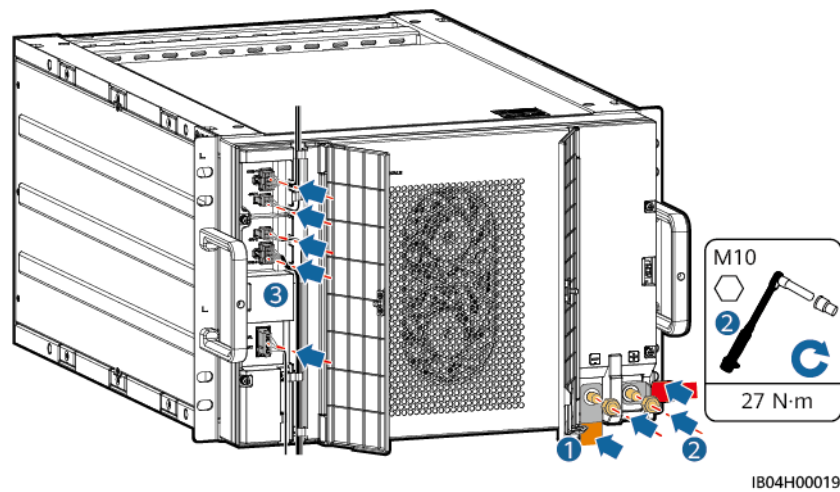

Step 12 Close the battery pack covers.

Figure 5-13 Closing the battery pack covers

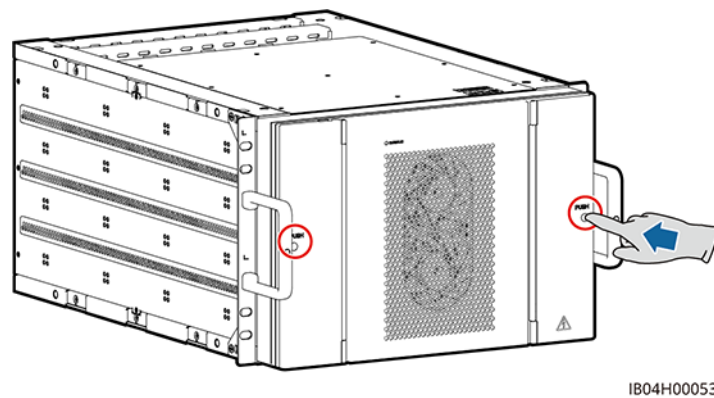

----End

Follow-up Procedure

- Step 1** Power on the system. For details, see the power-on section in the ESS user manual.
- Step 2** Log in to the CMU WebUI or SmartLogger WebUI, and choose **Maintenance > Software Upgrade** to upgrade the battery pack.

Figure 5-14 Upgrade

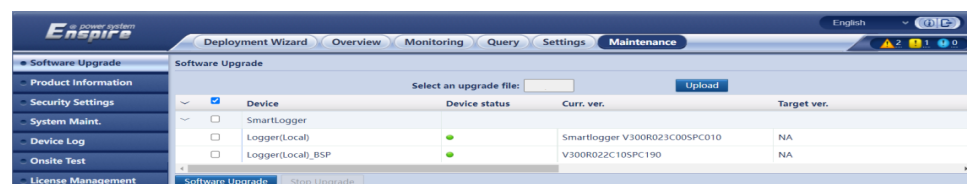

- Step 3** Check whether the functions are restored.

Check Item	Criteria
Alarm information	No major or minor component alarms are generated.
Function	The communication and charging/discharging functions are normal.
Running data	<ul style="list-style-type: none">• Number of modules: 12• Module voltage range: 43.2–58 V• Cell voltage range: 2.5–3.65 V• Module temperature range: -20°C to +55°C
Appearance	<ul style="list-style-type: none">• There is no obvious damage to the appearance.• There is no obvious paint peeling or rust.• The screws are secured.• The fans rotate properly without abnormal sound.• The front panel vent is clean and free from blockage.

----End

6 Replacing a Battery Pack Fan

Prerequisites

- Fault locating:
 - a. Log in to the SmartLogger WebUI, CMU WebUI, FusionSolar app, or management system to view alarm information.
 - b. Refer to the alarm handling suggestions in the alarm list.
- Tool: flat-head or Phillips insulated torque screwdriver
- Power off the ESS. For details, see [2.2 Powering Off a Single ESS](#).

Procedure

Step 1 Remove the fan and disconnect the cables.

Step 2 Install a new fan and connect the cables.

Step 3 Secure the fan cover.

----End

Follow-up Procedure

Step 1 Power on the system. For details, see the power-on section in the ESS user manual.

Step 2 Check the running status of the system and ensure that the functions are restored.

----End

7 Replacing a Smart PCS

Prerequisites

- Fault locating:
 - a. Log in to the SmartLogger WebUI, CMU WebUI, FusionSolar app, or management system to view alarm information.
 - b. Refer to the alarm handling suggestions in the alarm list.
- Power off the ESS. For details, see [2.2 Powering Off a Single ESS](#).
- At least four persons are required to replace the component.

For details about how to replace a Smart PCS, see the [LUNA2000-100KTL-M1 Smart Power Control System User Manual](#).

8 Replacing a Smart Rack Controller

Prerequisites

- Fault locating:
 - a. Log in to the SmartLogger WebUI, CMU WebUI, FusionSolar app, or management system to view alarm information.
 - b. Refer to the alarm handling suggestions in the alarm list.
- Tool: insulated torque socket wrench (including an extension bar)
- Power off the ESS. For details, see [2.2 Powering Off a Single ESS](#).
- At least three persons are required to replace the component.

Procedure

- Step 1** Remove the decorative cover and maintenance compartment cover from the rack controller.

Figure 8-1 Removing covers

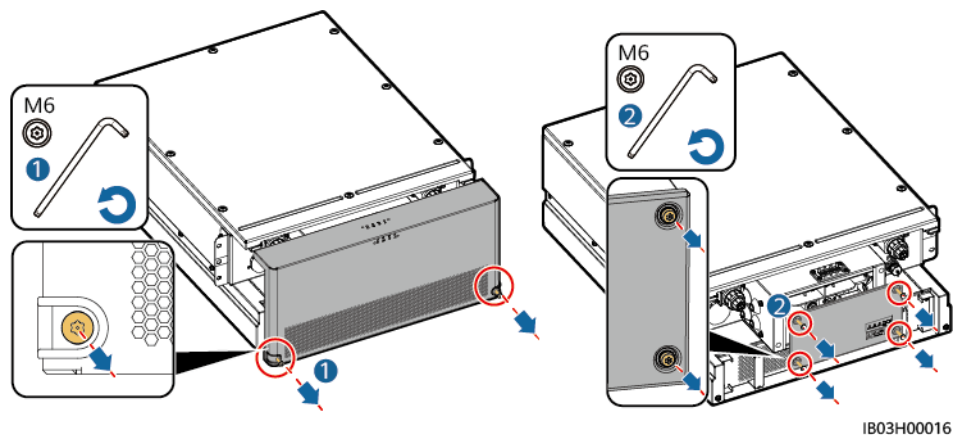

- Step 2** Remove cables from the BAT/BUS terminals, and then wrap the exposed terminals.

Figure 8-2 Removing the BAT/BUS terminal cables

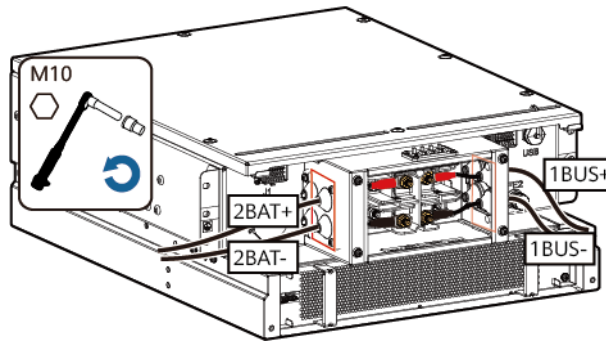

Step 3 Remove the J1 and J2 terminals, and the FE network cable.

Figure 8-3 Removing the J1 and J2 terminals, and the FE network cable

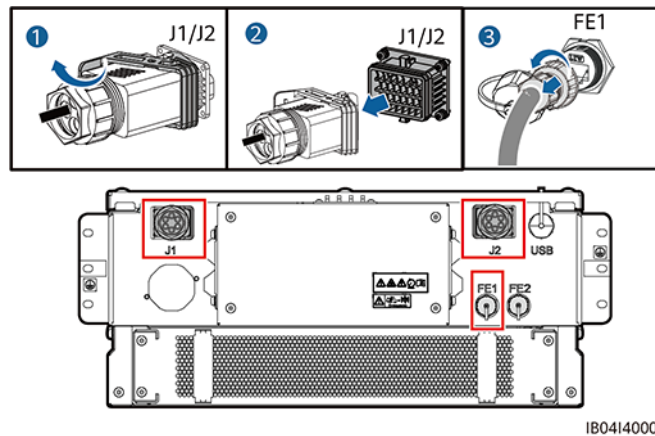

Step 4 Remove the short-circuiting copper bars.

Figure 8-4 Removing short-circuiting copper bars (200 kWh model)

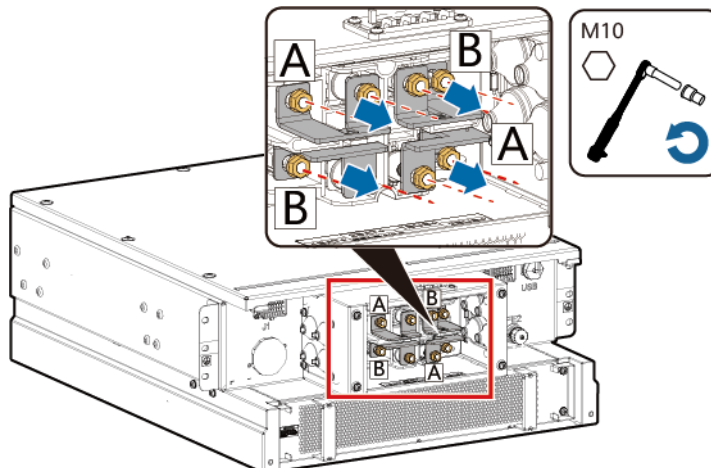
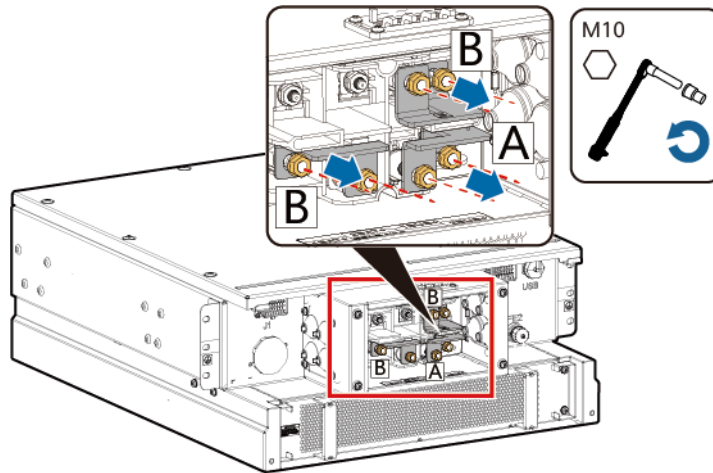
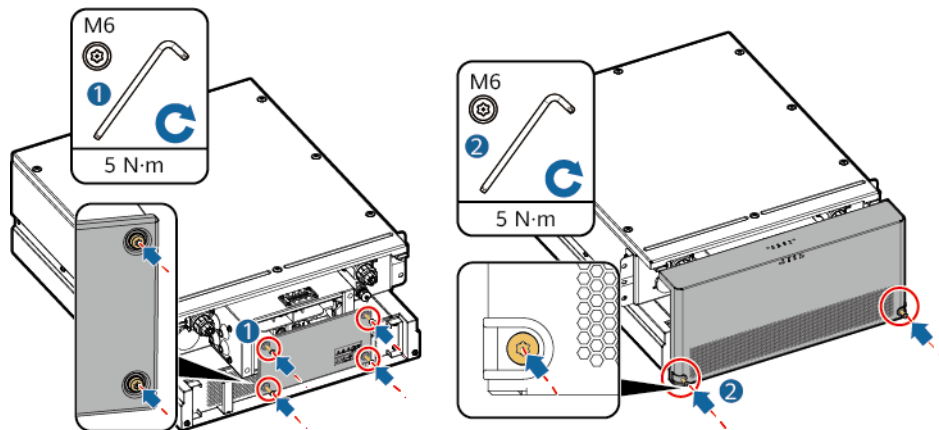

Figure 8-5 Removing short-circuiting copper bars (97 kWh/129 kWh/161 kWh model)



Step 5 Install the maintenance compartment cover and the decorative cover to the rack controller.

Figure 8-6 Installing covers



Step 6 Remove the ground cable and the delivered protective covers.

Figure 8-7 Removing the ground cable and protective covers

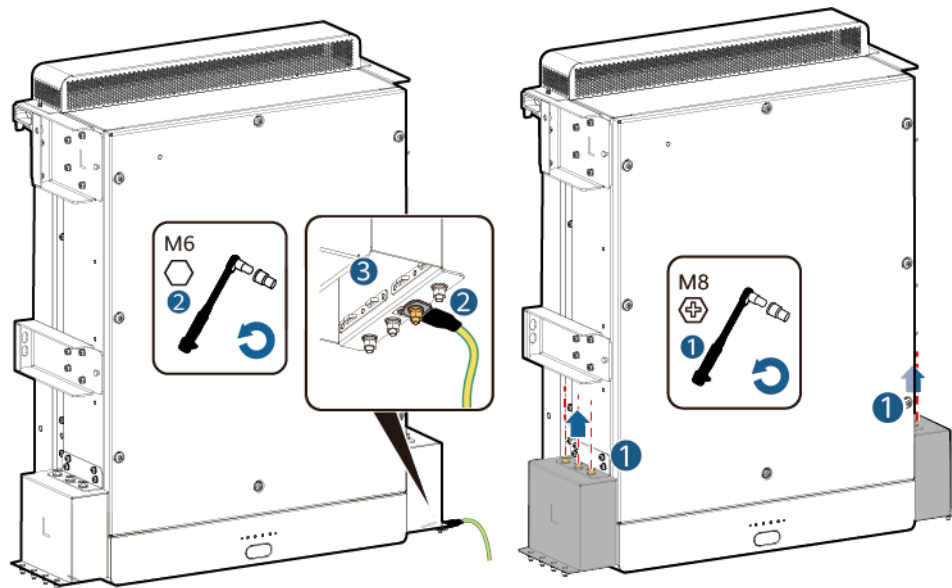

Step 7 Install the lifting handles and remove the rack controller.

NOTE

- At least four persons are required to move a battery pack.
- Secure the lifting handles (with the steel washers of the lifting handles closely fitted to the battery pack).
- If the stud of a lifting handle is bent, replace the lifting handle in time.
- When using the lifting handles delivered with the product, hold the end closer to the device.

Figure 8-8 Correct and incorrect lifting handle installation

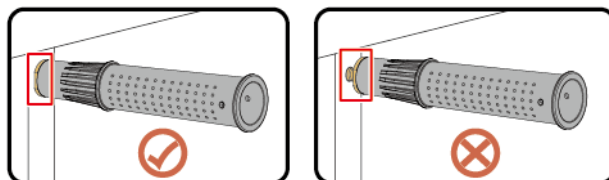

S000004

Figure 8-9 Removing the rack controller

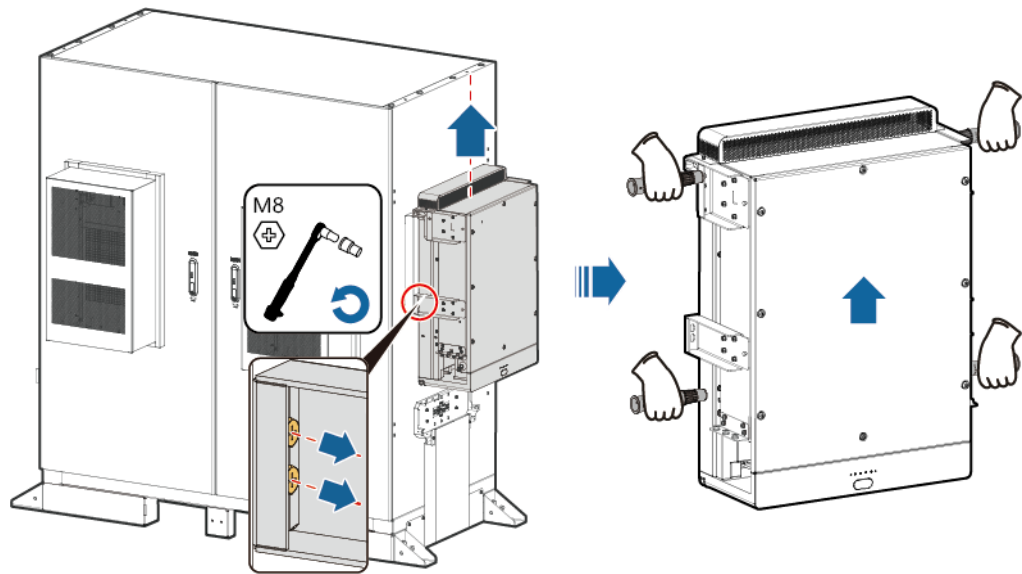

Step 8 Remove the upper brackets, lower brackets, and lifting handles from the rack controller.

Figure 8-10 Removing mounting kits

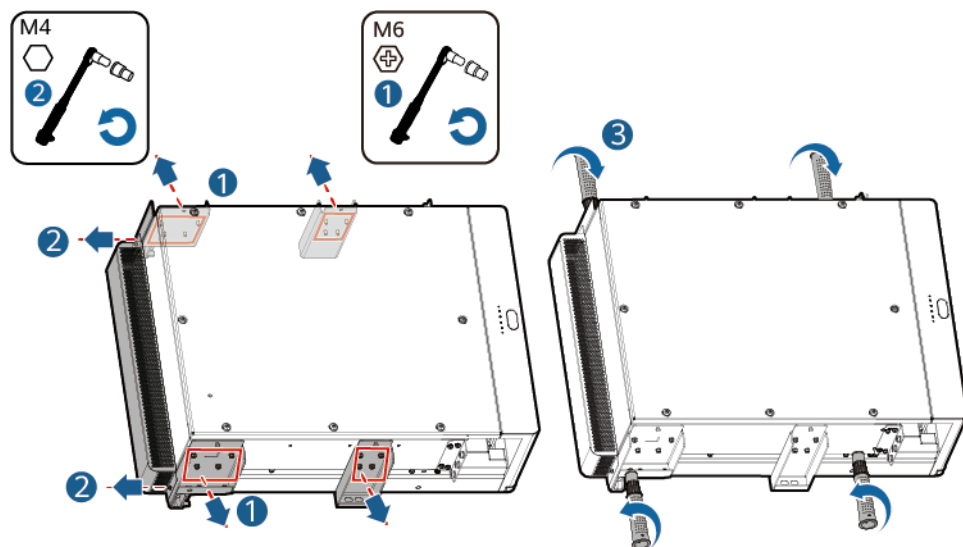

Step 9 Install the upper brackets, lower brackets, and lifting handles to a new rack controller.

Figure 8-11 Installing mounting kits

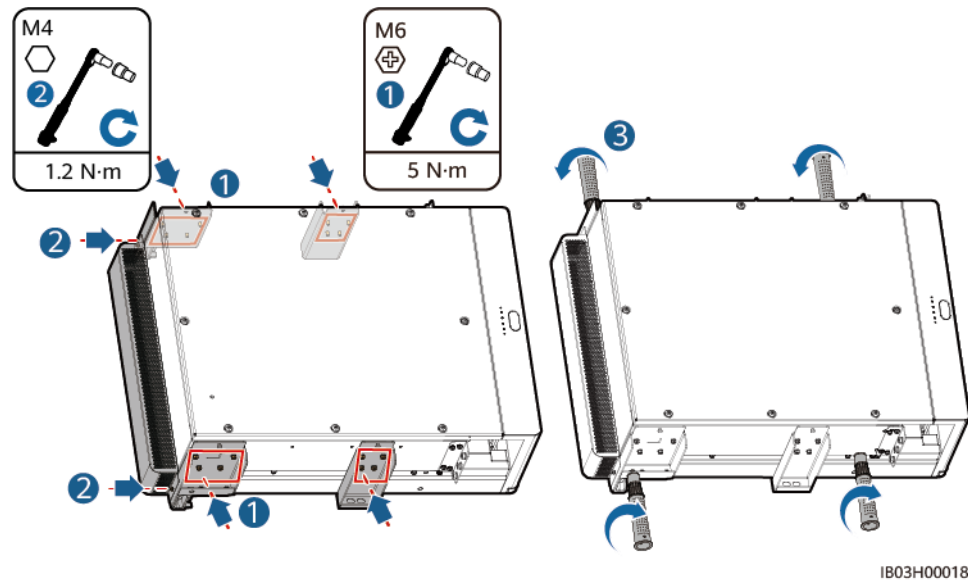

Step 10 Install the new rack controller to the mounting bracket on the ESS.

Figure 8-12 Installing the rack controller

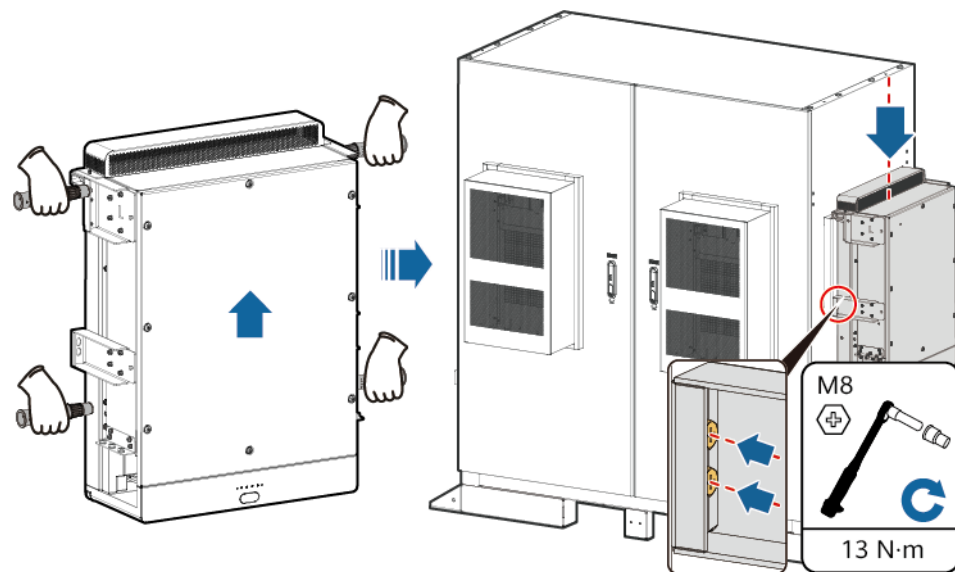

Step 11 Install the short-circuiting copper bars.

Figure 8-13 Installing short-circuiting copper bars (200 kWh model)

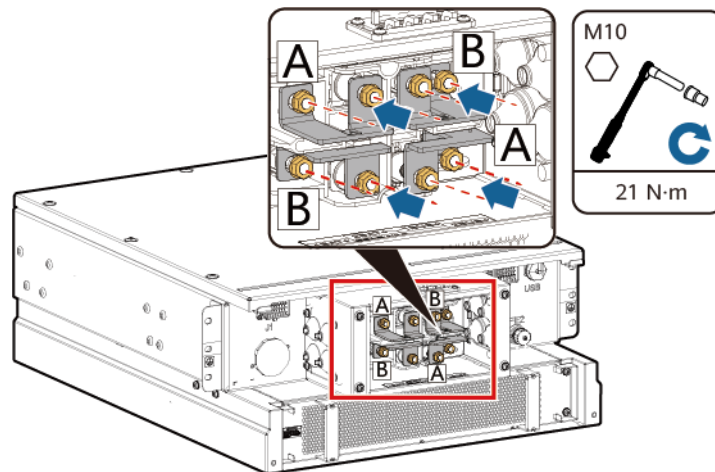

IB03H00019

Figure 8-14 Installing short-circuiting copper bars (97 kWh/129 kWh/161 kWh model)

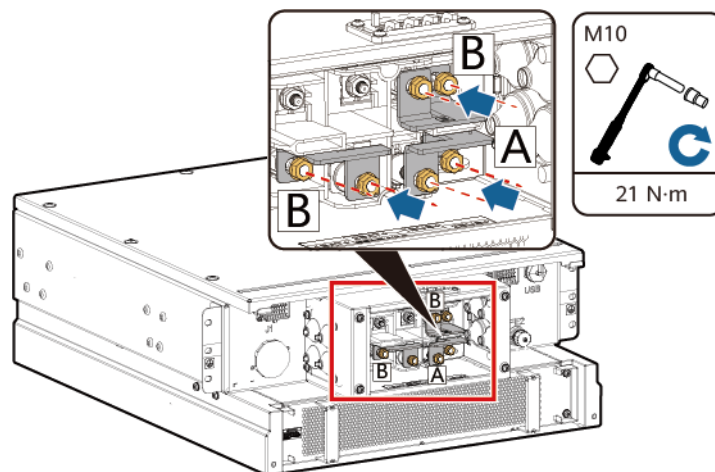

5000003

Step 12 Install cables to the BAT/BUS, J1, and J2 terminals, and FE network cable for the rack controller.

Figure 8-15 Installing cables (part 1)

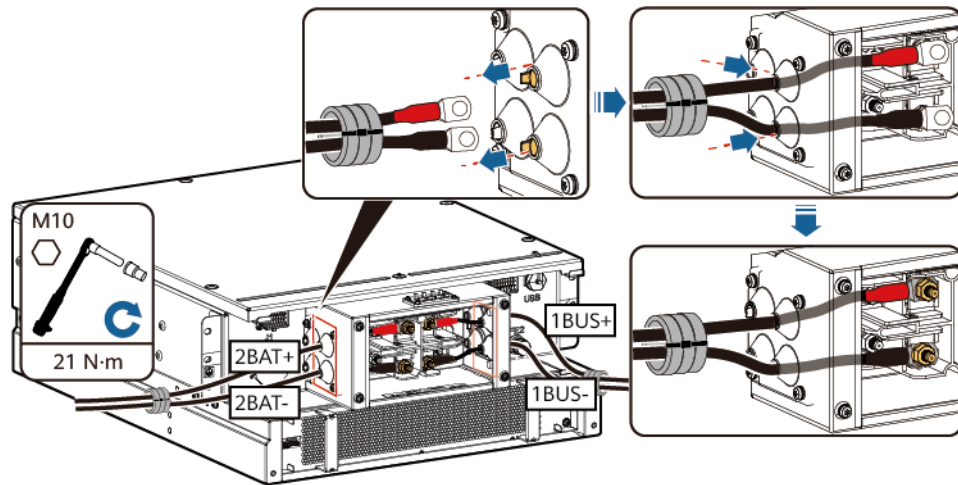
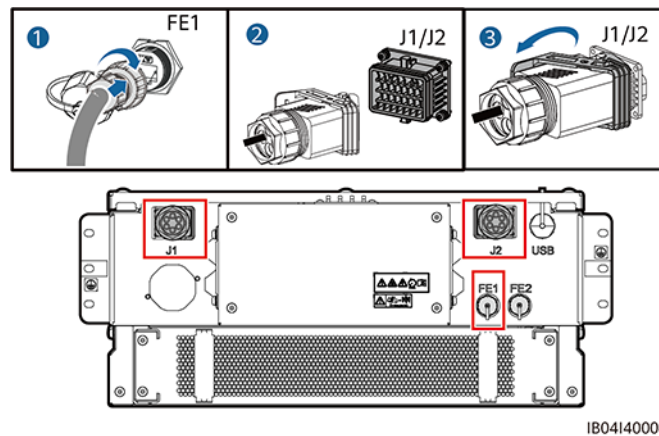
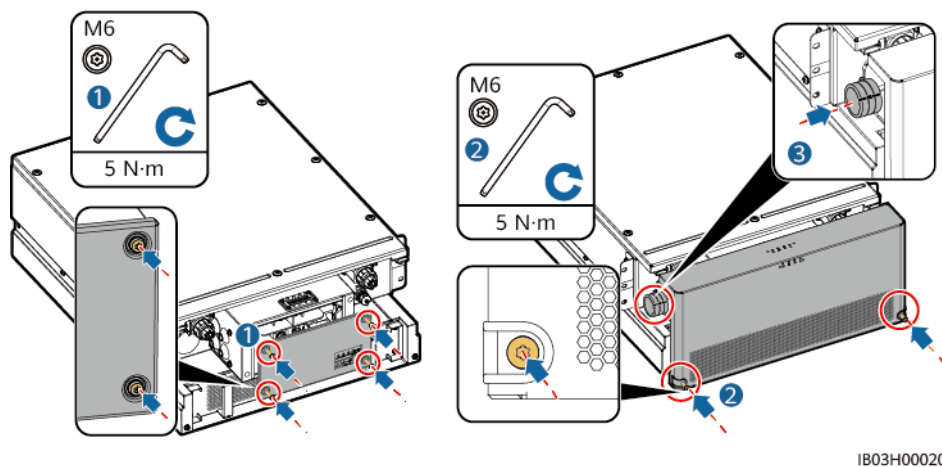

Figure 8-16 Installing cables (part 2)



Step 13 Install the maintenance compartment cover and decorative cover to the rack controller, and place the magnetic rings.

Figure 8-17 Installing covers



Step 14 Install the protective covers, connect the ground cable, and bind the cable. Bind and secure the magnetic rings and the protective covers.

Figure 8-18 Connecting the ground cable

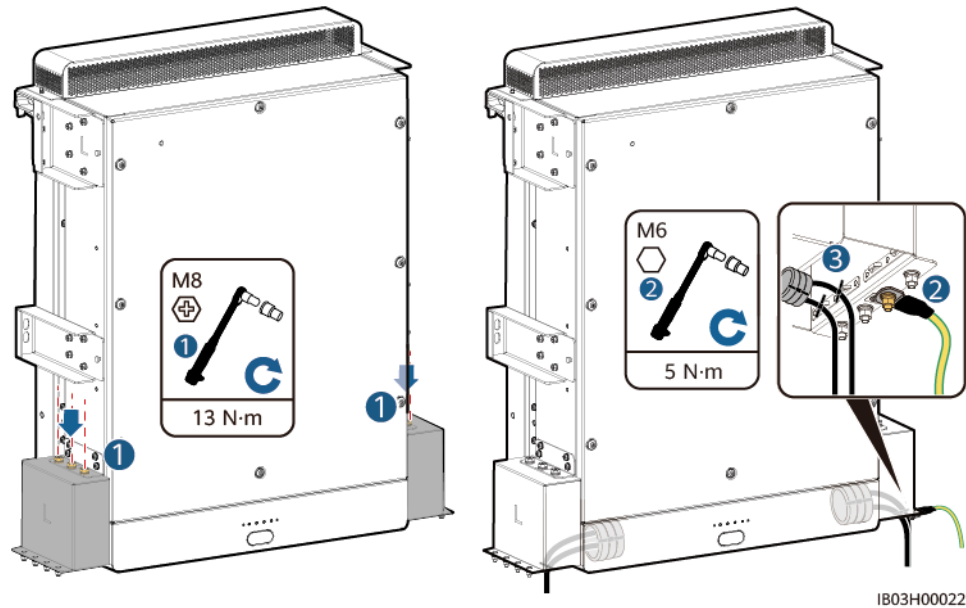

----End

Follow-up Procedure

- Step 1** Power on the system. For details, see the system power-on section in the [LUNA2000-\(97KWH-1H1, 129KWH-2H1, 161KWH-2H1, 200KWH-2H1\) Smart String ESS User Manual](#).
- Step 2** To delete an old device, log in to the CMU, choose **Maintenance > Connect Device**, select the old device, and delete it.

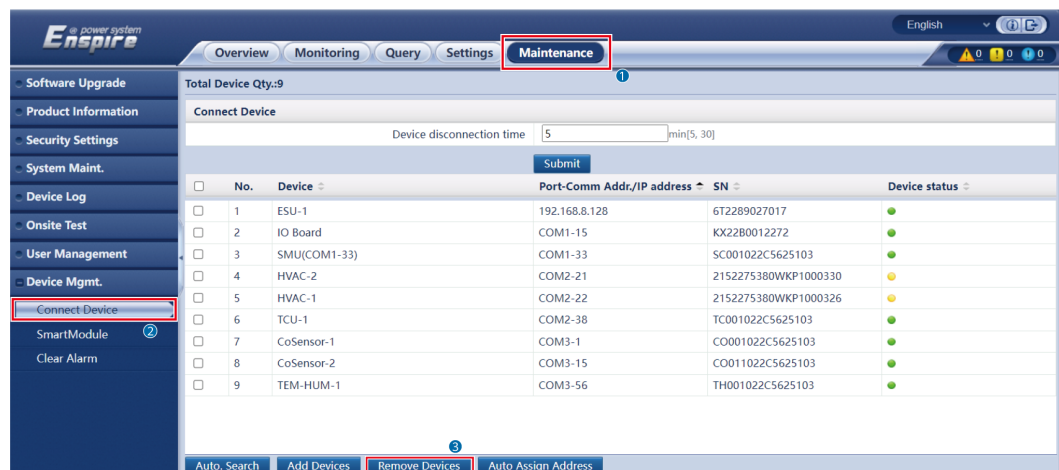

- Step 3** To delete invalid modules (**perform this step 2 minutes after the ESU is connected**), log in to the CMU, click **Monitoring**, and select the corresponding ESU. Click **Running Param.**, select **Delete invalid battery packs**, and click **Submit**.

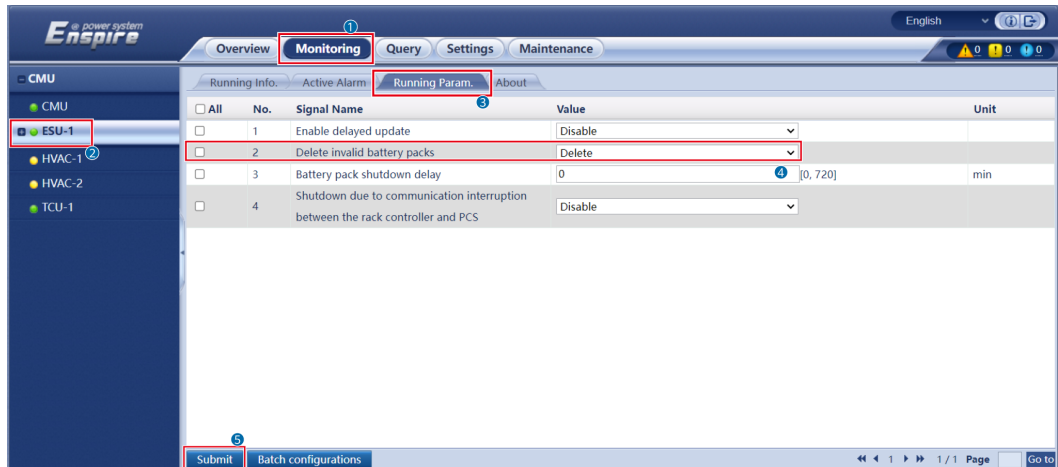

Step 4 Update the software version of the new Smart Rack Controller.

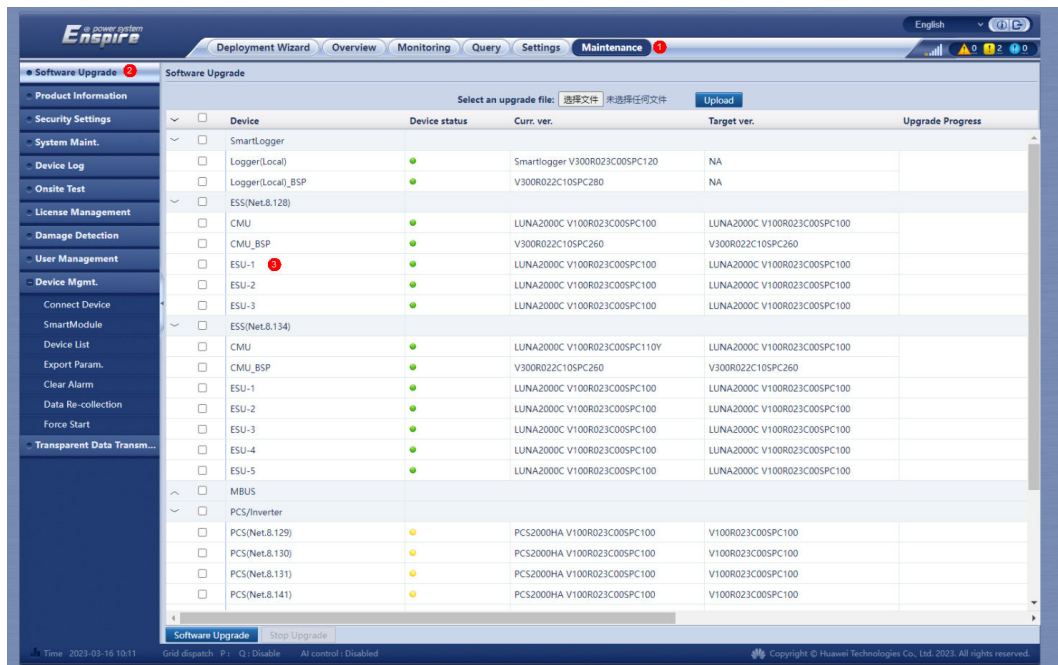

Step 5 Log in to the SmartLogger WebUI, delete the faulty ESS, and perform the search again.



Step 6 Click **Monitoring**, choose **Running Param.** > **Setting**, and set the ESS mode to no control and the active power control mode to no limit.

Step 7 On the **Deployment Wizard** page, click **Search for Device** to check cable connections and allocate addresses.

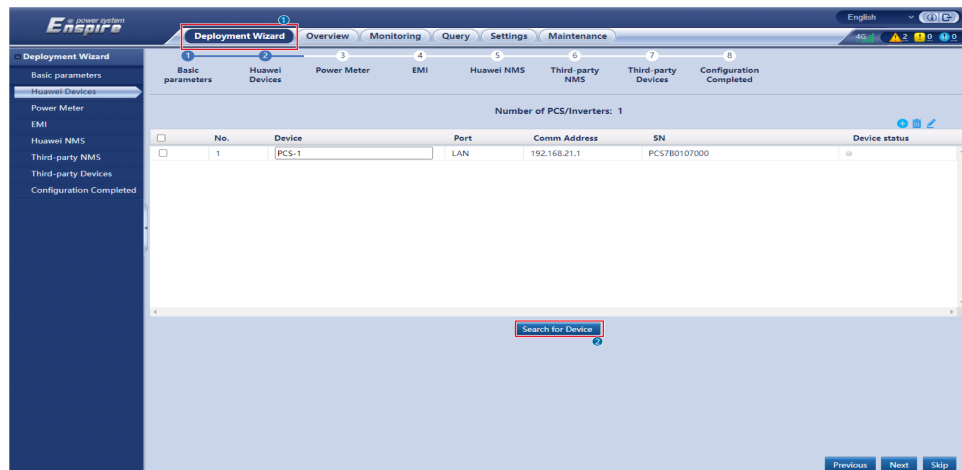
Figure 8-19 Searching for devices



 NOTE

- During the process of **Search for Device**, do not perform upgrade operations (such as upgrading through the app, management system, or WebUI).
- When you click **Search for Device**, cable connections (DC and AC) will be checked before device search (not applicable to third-party devices), and device addresses will be automatically allocated.
- After the cable connection check and device search are complete, if a cable connection alarm is generated, you can click the alarm icon  to view the corresponding alarm information.
- If an alarm is generated when the cable connection check fails, click the alarm icon  to view the alarm cause and handling suggestions. After the fault is rectified, check the cable connections again.
- After the cable connection check and device search are complete, click  to view the corresponding topology information.
- After a device is added or deleted, you need to click **Search for Device** again. Otherwise, the system topology will not be updated.

Step 8 Click **Monitoring**, select the old device, choose **Running Param.** > **Setting** > **All** > **Batch configurations**, select the new device, and click **Confirm** to synchronize data to the new device.

Figure 8-20 Batch configurations

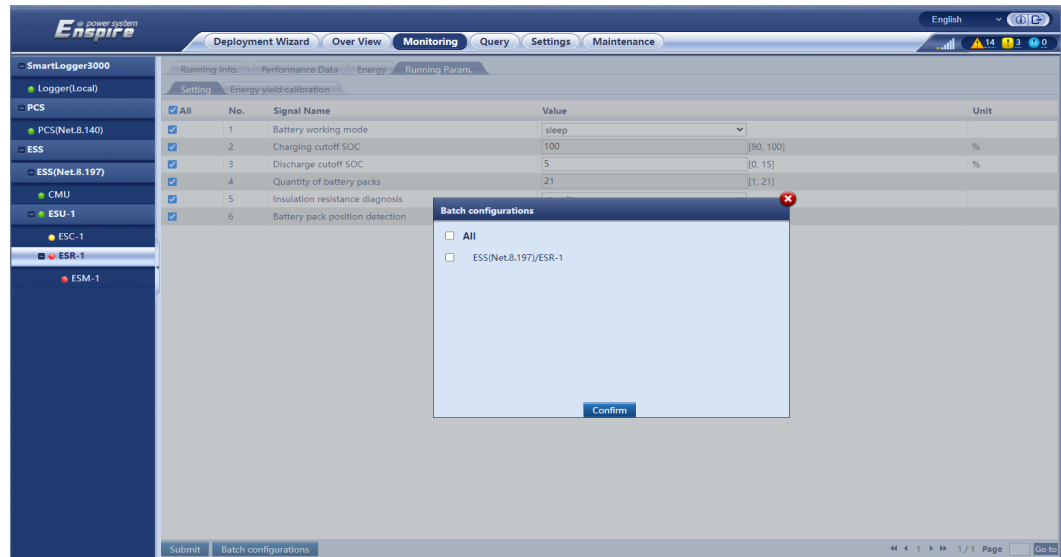

Step 9 Click **Energy yield calibration** and set **Total charged energy calibration** and **Total discharged energy calibration** to be the same as those of the old device.

Figure 8-21 Energy yield calibration

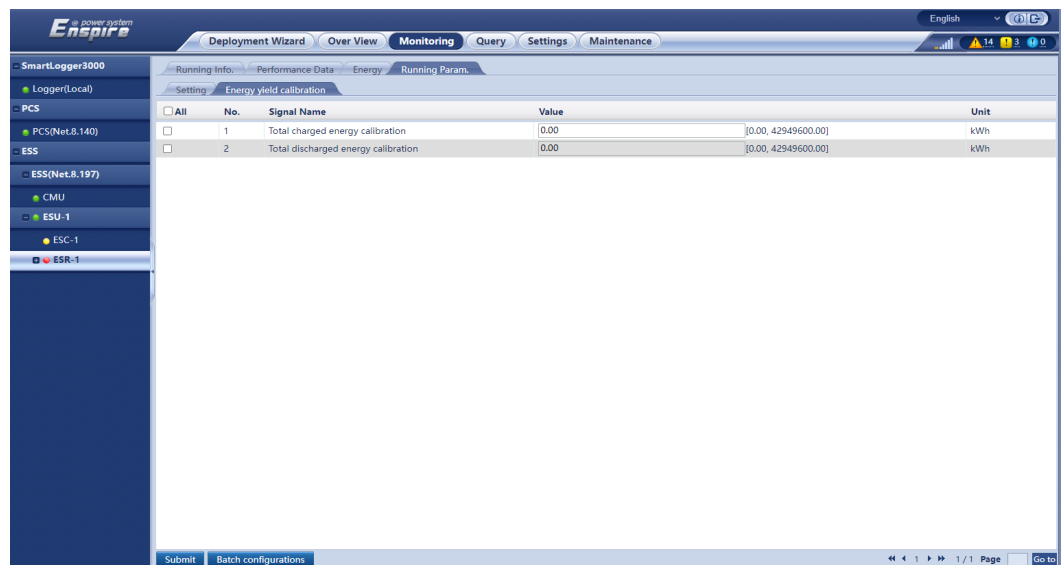

Step 10 Check the running status of the Smart Rack Controller and check whether it functions properly.

----End

9 Replacing a Rack Controller Fan

Prerequisites

- Fault locating:
 - a. Log in to the SmartLogger WebUI, CMU WebUI, FusionSolar app, or management system to view alarm information.
 - b. Refer to the alarm handling suggestions in the alarm list.
- Tools: Phillips insulated torque screwdriver, torx key
- Power off the ESS. For details, see [2.2 Powering Off a Single ESS](#).

Procedure

Step 1 Remove the decorative cover from the Smart Rack Controller.

Figure 9-1 Removing the decorative cover

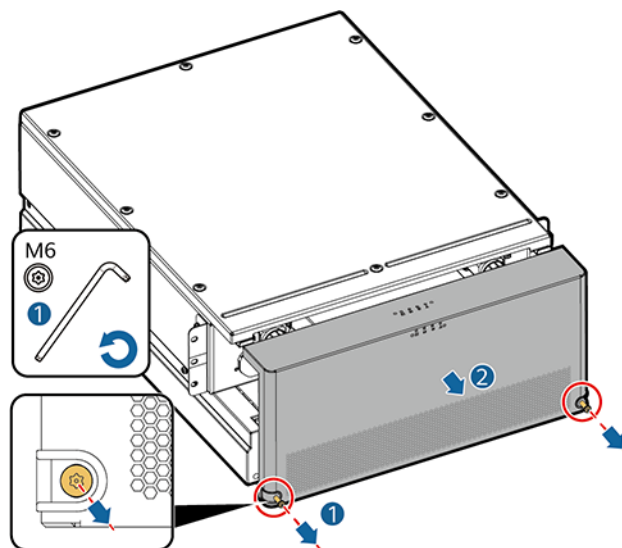

Step 2 Remove screws from the fan tray, and then pull it out.

Figure 9-2 Pulling out the fan tray

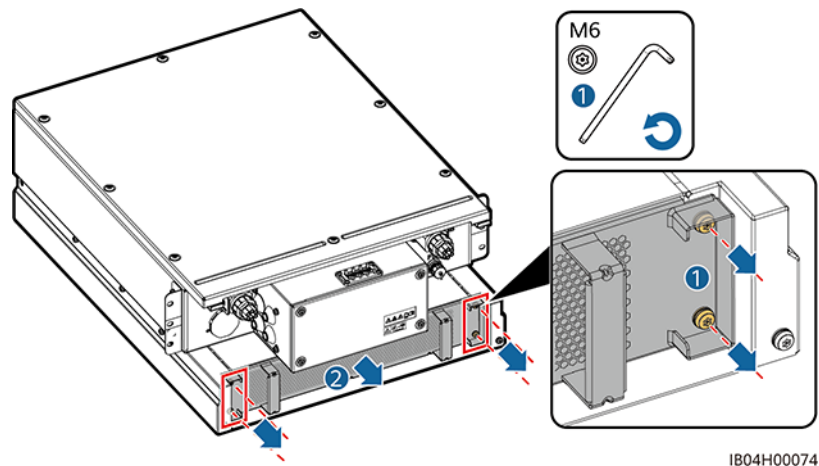

Step 3 Remove the cable ties around the cables, unscrew the connectors, and disconnect the cables.

Figure 9-3 Disconnecting cables

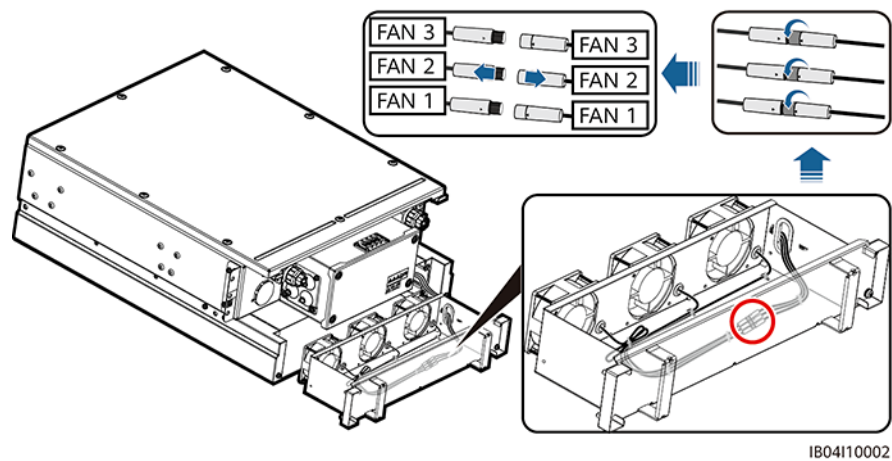

Step 4 Remove cable ties from the faulty fan.

- FAN 1 is faulty.

Figure 9-4 Removing the FAN 1 cable ties

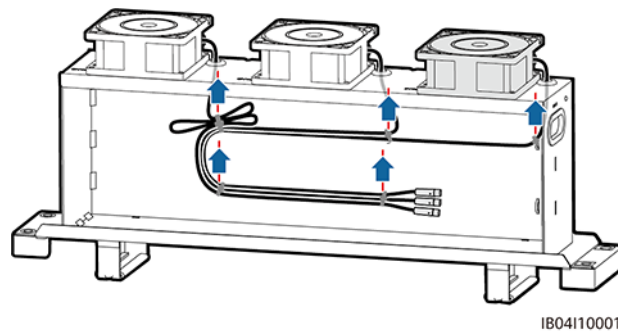

- FAN 2 is faulty.

Figure 9-5 Removing the FAN 2 cable ties

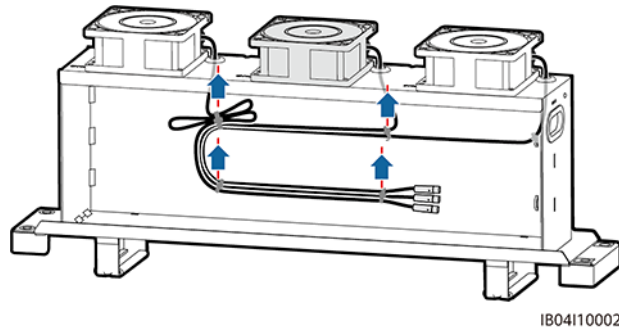

- FAN 3 is faulty.

Figure 9-6 Removing the FAN 3 cable ties

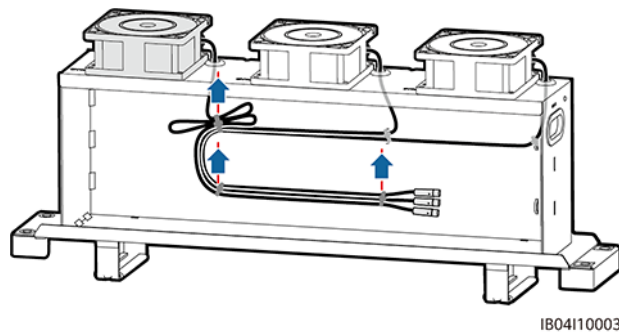

Step 5 Remove the faulty fan (FAN 1 is used as an example).

Figure 9-7 Removing the fan

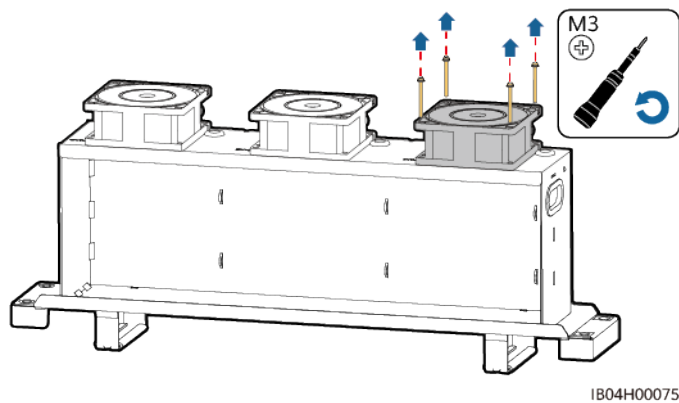

Step 6 Install a new fan (FAN 1 is used as an example).

Figure 9-8 Installing a fan

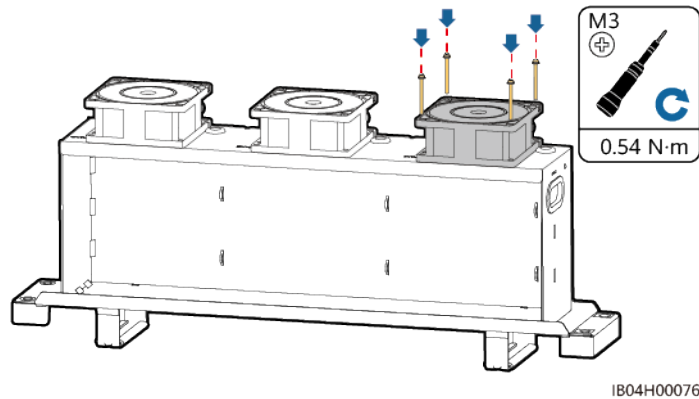

Step 7 Bind the fan cables.

- Binding positions for FAN 1

Figure 9-9 Binding the cables of FAN 1

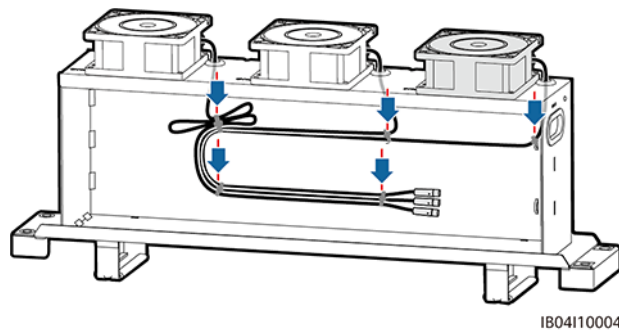

- Binding positions for FAN 2

Figure 9-10 Binding the cables of FAN 2

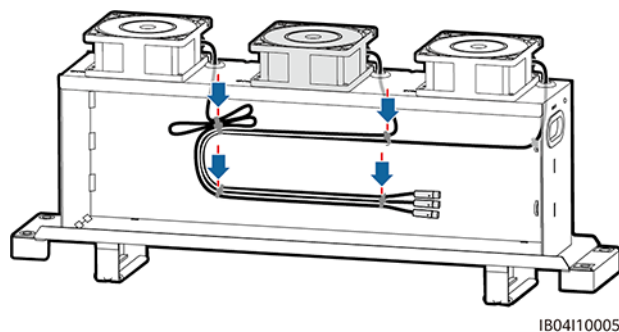

- Binding position for FAN 3

Figure 9-11 Binding the cable of FAN 3

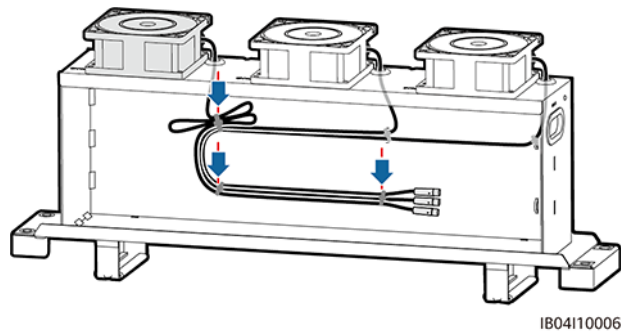

Step 8 Connect the cables correctly according to the cable labels and bind the cables.

Figure 9-12 Binding cables

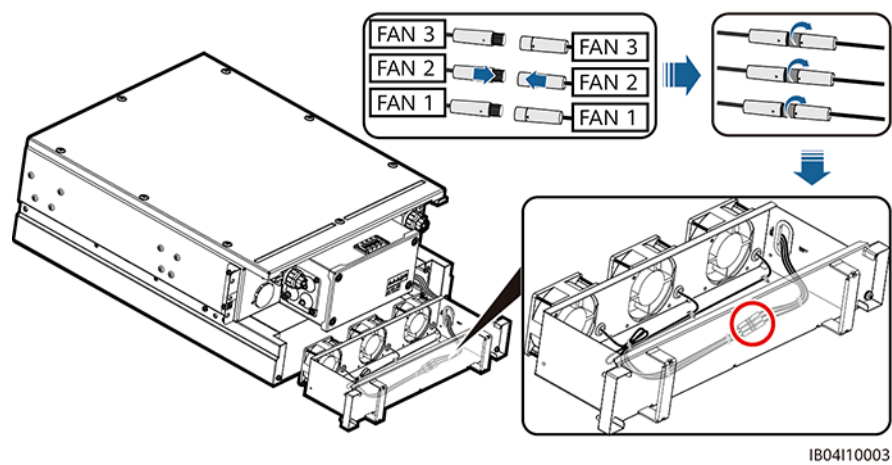

Step 9 Push the fan tray into the slot and tighten the screw.

Figure 9-13 Reinstalling the fan tray

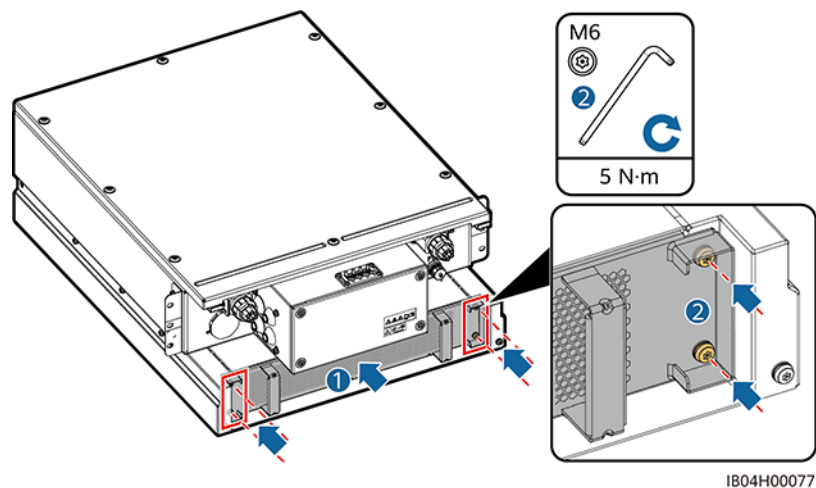

----End

Follow-up Procedure

- Step 1** Turn on DC/DC switch 2FCB1 in the cabinet.
 - Step 2** Log in to the SmartLogger WebUI, CMU WebUI, FusionSolar app, or management system and send a startup command to the rack controller.
 - Step 3** Check that the alarm is cleared.
 - Step 4** Turn on DC switch 1Q1 in the cabinet.
 - Step 5** Turn on DC switch 1Q2 in the cabinet.
 - Step 6** Check the running status of the rack controller and check whether it functions properly.
- End

10 Replacing an Air Conditioner

10.1 Replacing an Air Conditioner Internal Fan

Prerequisites

- Fault locating:
 - a. Log in to the SmartLogger WebUI, CMU WebUI, FusionSolar app, or management system to view alarm information.
 - b. Refer to the alarm handling suggestions in the alarm list.
- Tools: flat-head or Phillips insulated torque screwdriver, insulated torque socket wrench, multimeter
- Power-off: Turn off the power switch of the air conditioner in the cabinet.

NOTE

The power loop of the ESS does not need to be powered off. You are advised to set the ESS in standby or shutdown mode during replacement.

Procedure

Step 1 Remove the air duct.

Figure 10-1 Removing the air duct

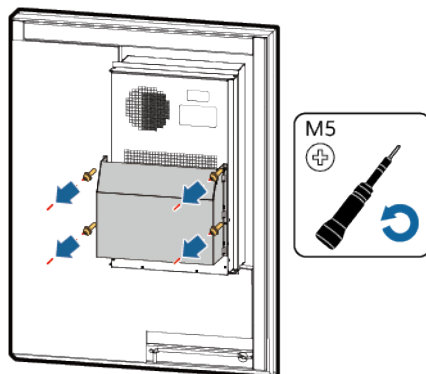

IB04H00105

Step 2 Remove cables from the air conditioner.

Figure 10-2 Removing air conditioner cables

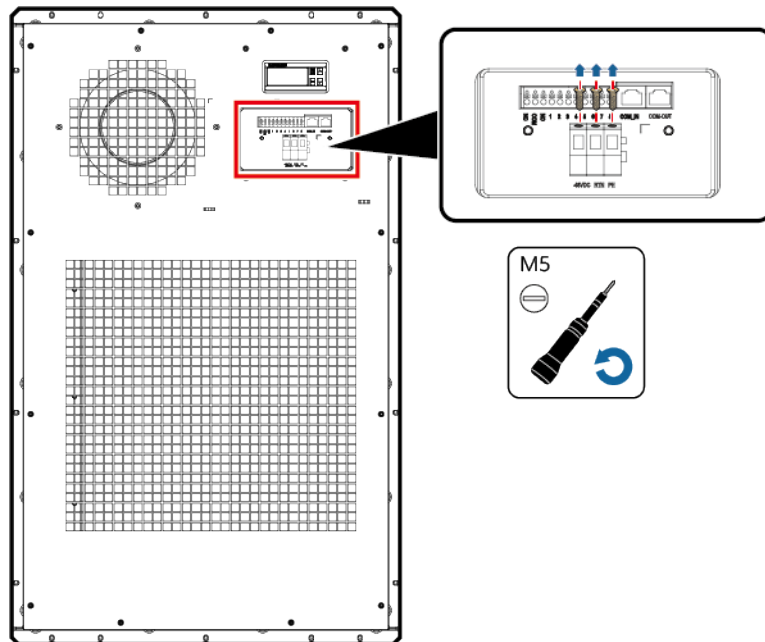

IB04H00106

Step 3 Remove the front cover of the air conditioner.

Figure 10-3 Removing the front cover of the air conditioner

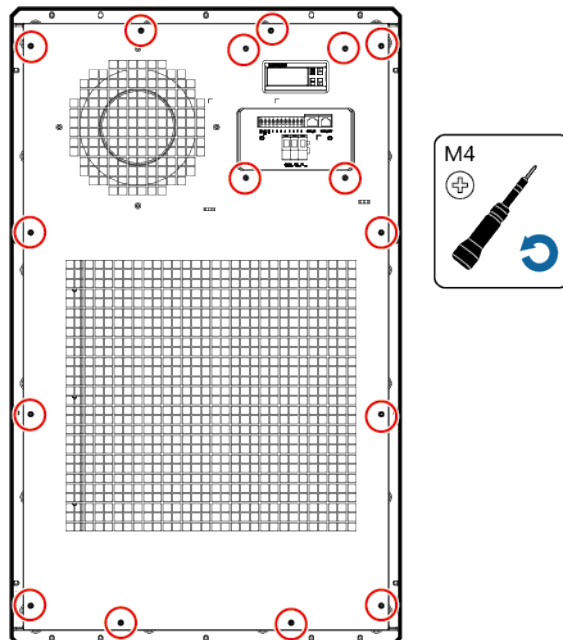

IB04H00107

Step 4 Remove the screws from the fixing plate of the internal fan, and then remove the internal fan and the fixing plate.

Figure 10-4 Removing the internal fan and the fixing plate

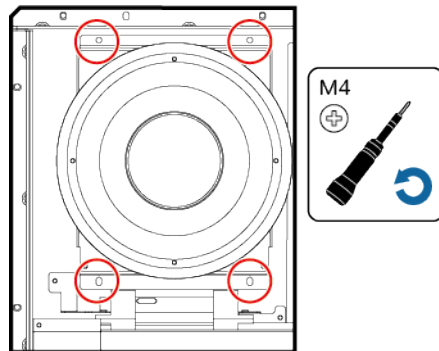

IB04H00108

Step 5 Remove the internal fan cable from the main control board.

Figure 10-5 Removing the internal fan cable

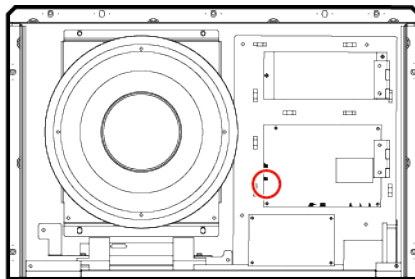

Step 6 Remove the internal fan from the fixing plate.

Figure 10-6 Removing the internal fan

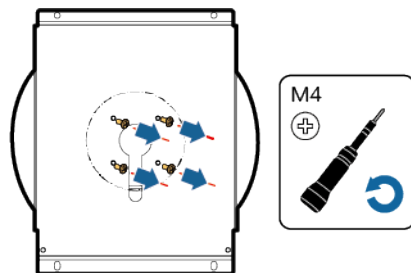

IB04H00110

Step 7 Install a new internal fan on the fixing plate.

Step 8 Install the fixing plate.

Step 9 Connect and arrange the internal fan cable bundle to the main control board.

Step 10 Install the front cover.

Step 11 Install the air conditioner cables.

Step 12 Install the air duct.

----End

Follow-up Procedure

Step 1 Turn on the power switch of the air conditioner in the cabinet.

Step 2 Check whether the functions are restored.

Check Item	Criteria
Alarm information	There is no alarm related to the internal fan.
Function	Low-speed operation in air supply mode and high-speed operation in cooling mode
Running data	Internal fan status: normal operation

----End

10.2 Replacing an Air Conditioner External Fan

Prerequisites

- Fault locating:
 - a. Log in to the SmartLogger WebUI, CMU WebUI, FusionSolar app, or management system to view alarm information.
 - b. Refer to the alarm handling suggestions in the alarm list.
- Tools: Phillips insulated torque screwdriver, insulated torque socket wrench, T20 security torx screwdriver, multimeter, utility knife
- Power-off: Turn off the power switch of the air conditioner in the cabinet.

NOTE

The power loop of the ESS does not need to be powered off. You are advised to set the ESS in standby or shutdown mode during replacement.

Procedure

Step 1 Remove the rear cover of the air conditioner, and use a dedicated T20 security torx screwdriver to remove the two security torx screws from the bottom.

Figure 10-7 Removing security torx screws

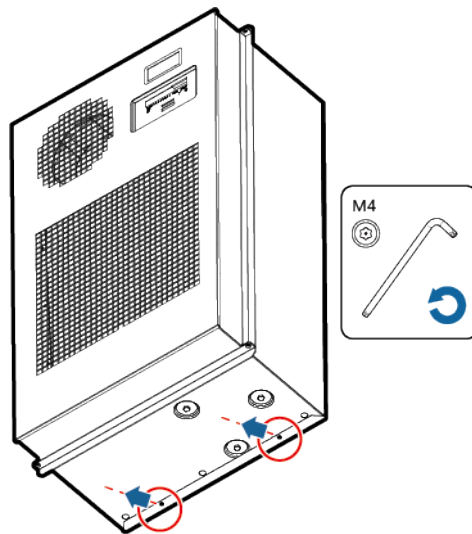

Step 2 Remove the two screws from the upper part of the external fan fixing plate and the two nuts from the lower part. Then, remove the external fan and the fixing plate.

Figure 10-8 Removing the external fan and the fixing plate

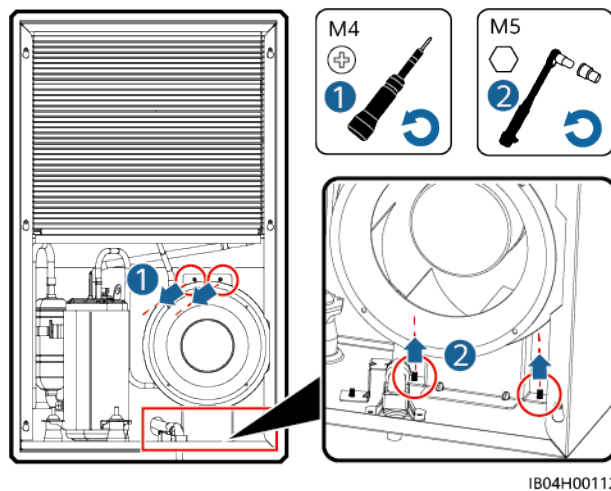

Step 3 Remove cables from the quick connect port of the external fan, and remove the external fan from the support.

Figure 10-9 Removing the external fan

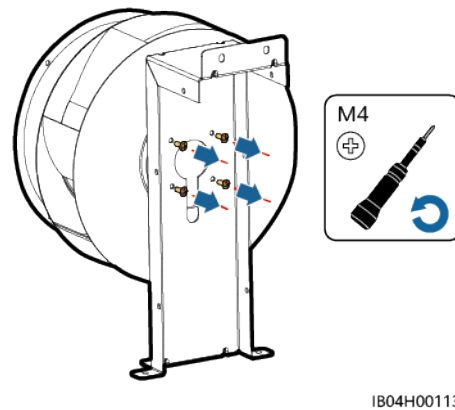

Step 4 Install a new external fan.

Step 5 Connect and arrange the external fan cable bundle.

Step 6 Install the rear cover.

----End

Follow-up Procedure

Step 1 Turn on the power switch of the air conditioner in the cabinet.

Step 2 Check whether the functions are restored.

Check Item	Criteria
Alarm information	There is no alarm related to the external fan.
Function	The rotation speed is adjusted automatically according to the condensing pressure.
Running data	External fan status: standby when no cooling is required, and normal when cooling is required.

----End

10.3 Replacing an Air Conditioner Main Control Board

Prerequisites

- Fault locating:
 - a. Log in to the SmartLogger WebUI, CMU WebUI, FusionSolar app, or management system to view alarm information.
 - b. Refer to the alarm handling suggestions in the alarm list.
- Tools: flat-head or Phillips insulated torque screwdriver, multimeter
- Power-off: Turn off the power switch of the air conditioner in the cabinet.

 **NOTE**

The power loop of the ESS does not need to be powered off. You are advised to set the ESS in standby or shutdown mode during replacement.

Procedure

Step 1 Remove the air duct.

Figure 10-10 Removing the air duct

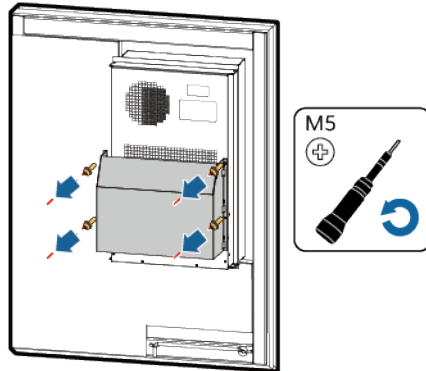

Step 2 Remove cables from the air conditioner.

Figure 10-11 Removing air conditioner cables

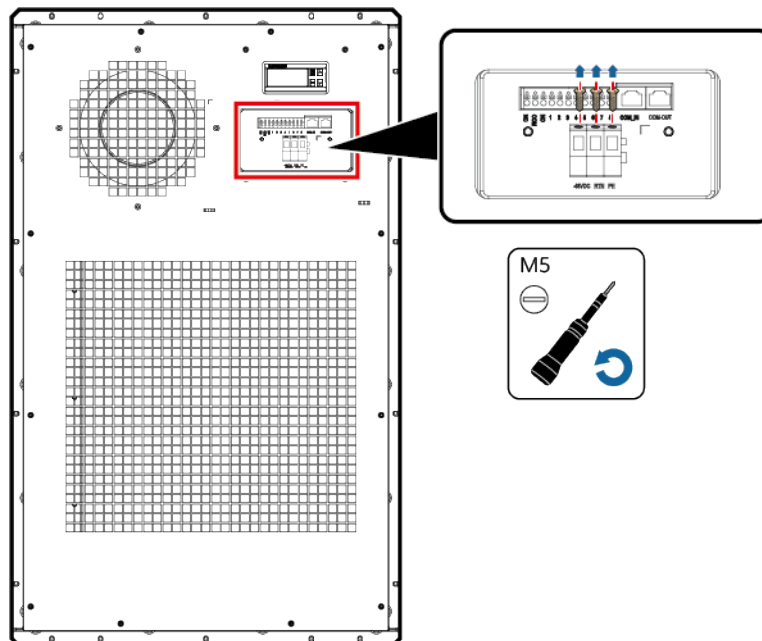

Step 3 Remove the front cover of the air conditioner.

Figure 10-12 Removing the front cover of the air conditioner

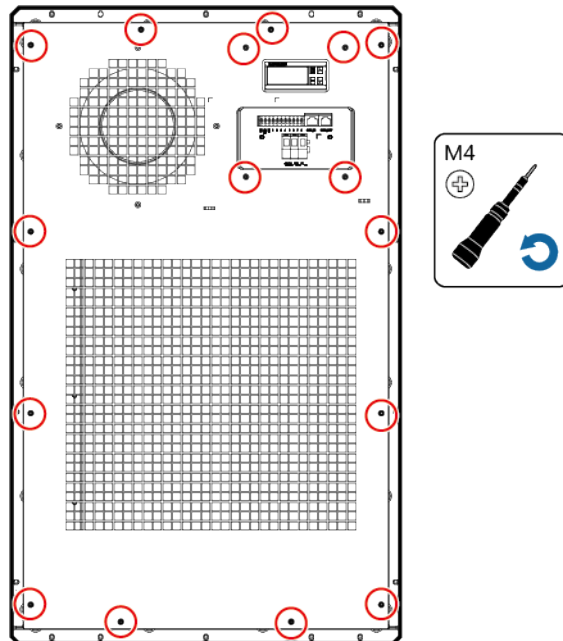

IB04H00107

Step 4 Remove all cables from the main control board.

NOTE

As some terminal connectors on the main control board are secured with transparent adhesive, you need to use a utility knife to remove the transparent adhesive.

Step 5 Remove the main control board.

Figure 10-13 Removing the main control board

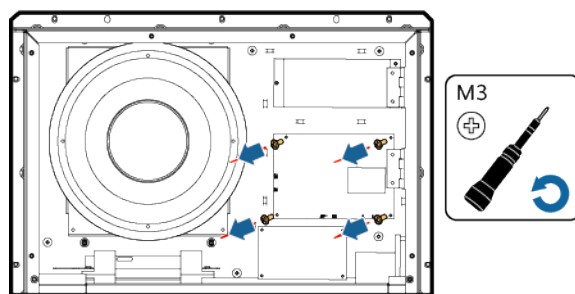

IB04H00114

Step 6 Install a new main control board.

Step 7 Reinstall the cables of the main control board.

Step 8 Install the front cover.

Step 9 Connect the air conditioner cables.

Step 10 Install the air duct for the air conditioner.

----End

Follow-up Procedure

- Step 1** Turn on the power switch of the air conditioner in the cabinet.
- Step 2** Log in to the CMU, choose **Maintenance > Connect Device > Remove Devices**, and remove the old air conditioner.

Figure 10-14 Removing the old air conditioner

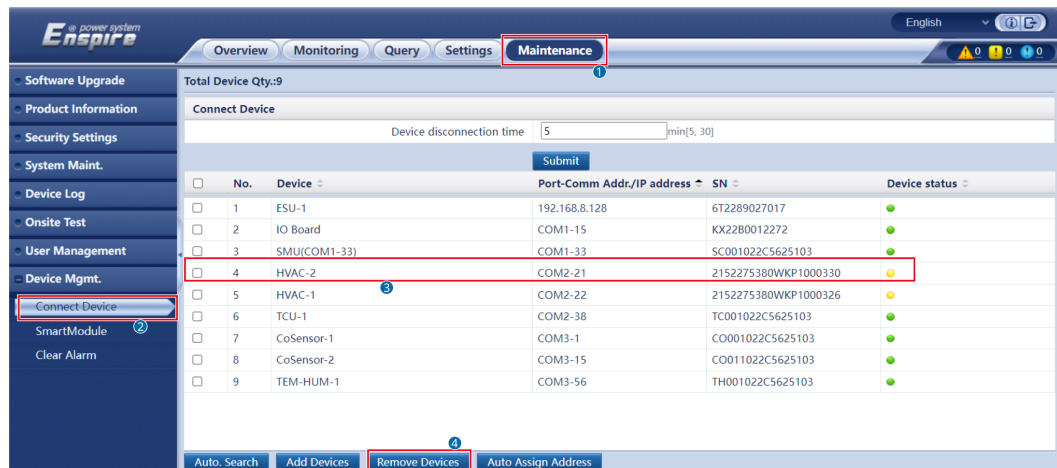

- Step 3** Click **Auto Search** and add the new air conditioner.

Figure 10-15 Adding the new air conditioner

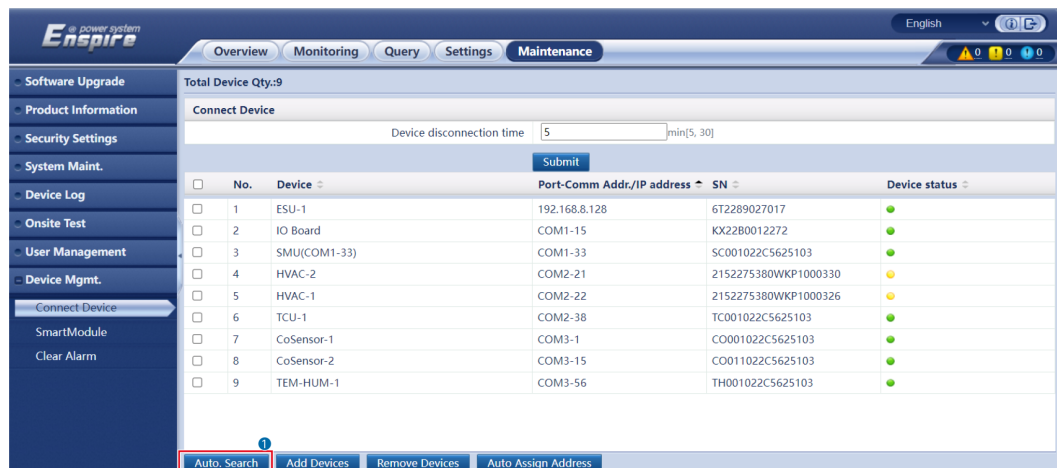

- Step 4** Check whether the functions are restored.

Check Item	Criteria
Alarm information	No component communication alarm is generated.
Function	The functions are normal.
Running data	Air conditioner status: normal operation

----End

10.4 Replacing an Air Conditioner

Prerequisites

- Fault locating:
 - a. Log in to the SmartLogger WebUI, CMU WebUI, FusionSolar app, or management system to view alarm information.
 - b. Refer to the alarm handling suggestions in the alarm list.
- Tools: flat-head or Phillips insulated torque screwdriver, multimeter
- Power-off: Turn off the power switch of the air conditioner in the cabinet.

NOTE

The power loop of the ESS does not need to be powered off. You are advised to set the ESS in standby or shutdown mode during replacement.

- At least two persons are required to replace the component.

Procedure

Step 1 Remove the air duct.

Figure 10-16 Removing the air duct

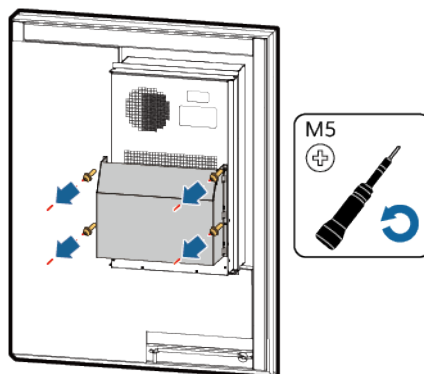

IB04H00105

Step 2 Remove cables from the air conditioner.

Figure 10-17 Removing air conditioner cables

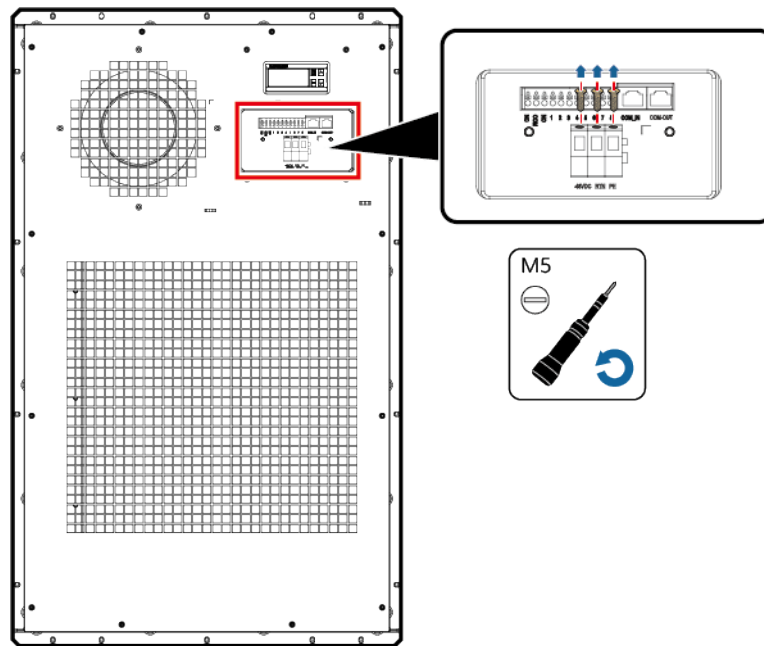

IB04H00106

Step 3 Remove screws and sealing tapes, and then remove the old air conditioner.

Figure 10-18 Removing the old air conditioner

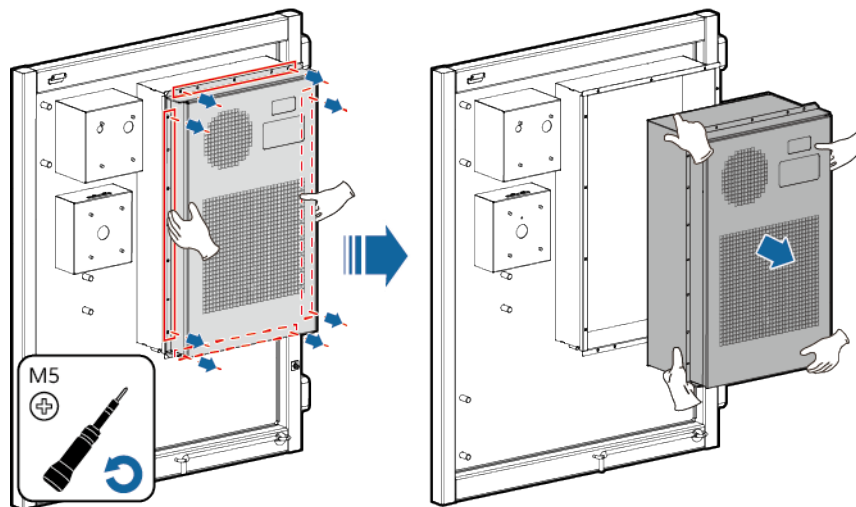

IB04H00115

Step 4 Remove the remaining sealing tapes from the door frame.

Step 5 Install a new air conditioner.

Figure 10-19 Installing a new air conditioner

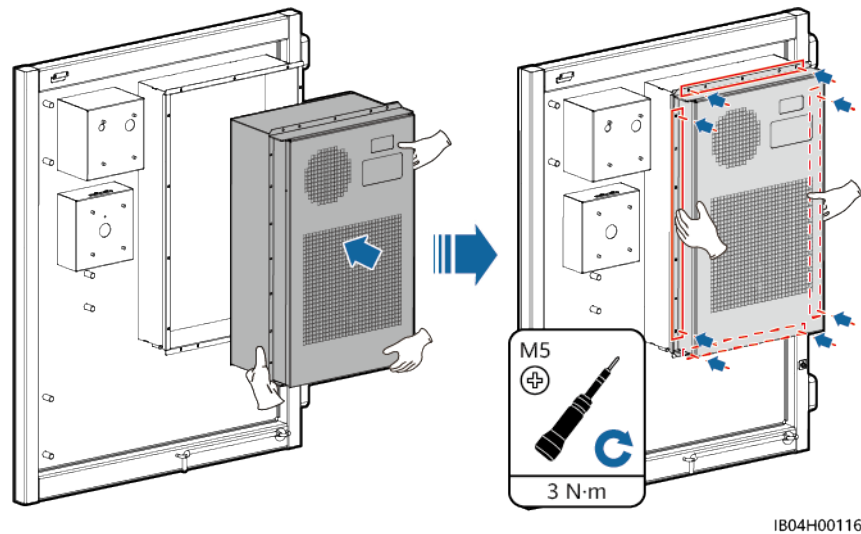

Step 6 Connect the air conditioner cables.

Step 7 Install the air duct. Use an M5 Phillips insulated torque screwdriver with a torque of 3 N·m.

----End

Follow-up Procedure

Step 1 Turn on the power switch of the air conditioner in the cabinet.

Step 2 Log in to the CMU, choose **Maintenance > Connect Device > Remove Devices**, and remove the old air conditioner.

Figure 10-20 Removing the old air conditioner

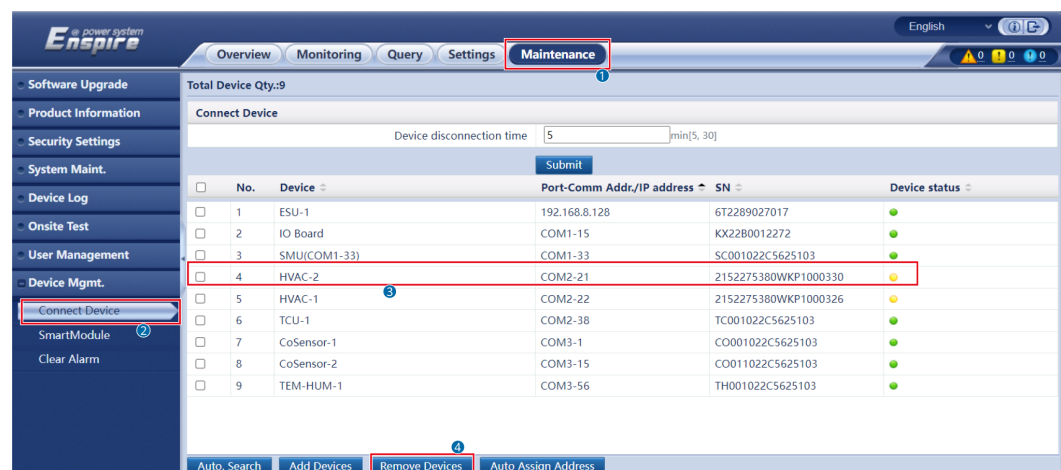

Step 3 Click **Auto. Search** and add the new air conditioner.

Figure 10-21 Adding the new air conditioner

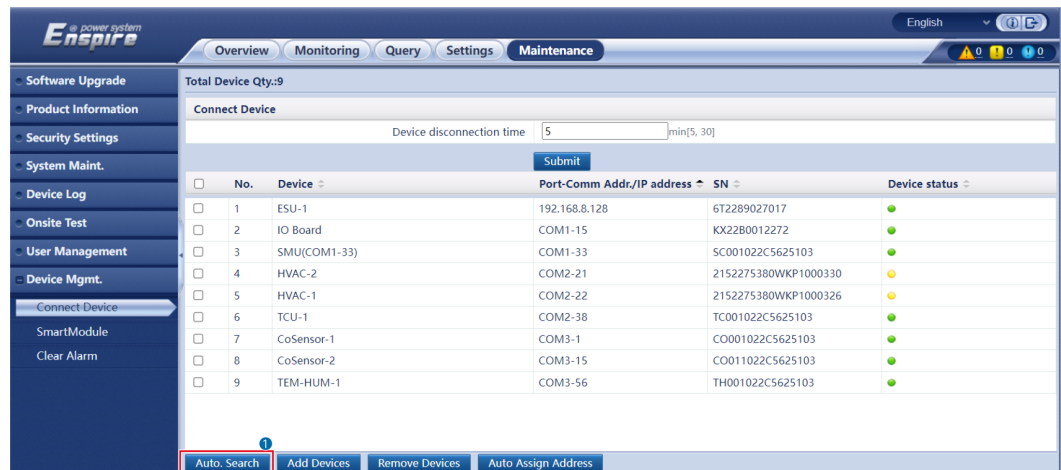

Step 4 Check whether the functions are restored.

Check Item	Criteria
Alarm information	No component communication alarm is generated.
Function	The functions are normal.
Running data	Air conditioner status: normal operation

----End

11 Replacing a Light

Prerequisites

- Fault locating: If the power supply is normal but the light is off, the light is damaged.
- Tools: flat-head or Phillips insulated torque screwdriver, cable cutter, insulation tape
- Power-off: Turn off the DC switch of the light in the ESS.

Procedure

Step 1 Remove the faulty light.

 **CAUTION**

During replacement, do not touch the ends of the light with bare hands. Otherwise, electric shocks may occur.

Step 2 Install a new light in the original position.

----End

Follow-up Procedure

Step 1 Turn on the DC switch of the light in the ESS.

Step 2 Check whether the lighting function is restored.

----End

12 Replacing a Fuse

Prerequisites

- Fault locating:

Symptom	Possible Cause	Troubleshooting
A circuit breaker is faulty due to overcurrent or a short circuit.	<ol style="list-style-type: none">1. The circuit breaker is in a position between ON and OFF.2. The circuit breaker is faulty.	<ol style="list-style-type: none">1. Set the circuit breaker to OFF and then to ON.2. Replace the circuit breaker.

- Tool: insulated torque socket wrench
- Power off the ESS. For details, see [2.2 Powering Off a Single ESS](#).

Procedure

- Step 1** Remove the fuse.

Figure 12-1 Removing the fuse

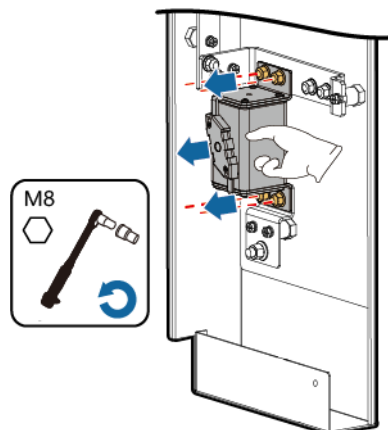

- Step 2** Install a new fuse.

Figure 12-2 Installing a new fuse

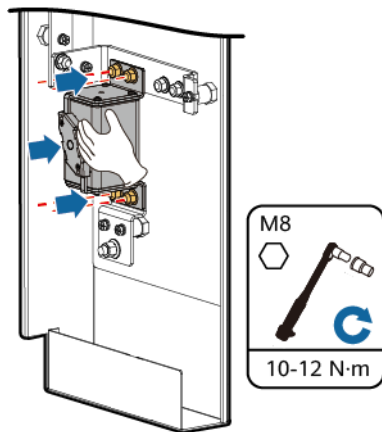

----End

Follow-up Procedure

- Step 1** Power on the system. For details, see the power-on section in the ESS user manual.
- Step 2** Check the running status of the system and ensure that the functions are restored.

----End

13 Replacing a Circuit Breaker

13.1 Replacing a DC Switch

Figure 13-1 Position of the DC switch

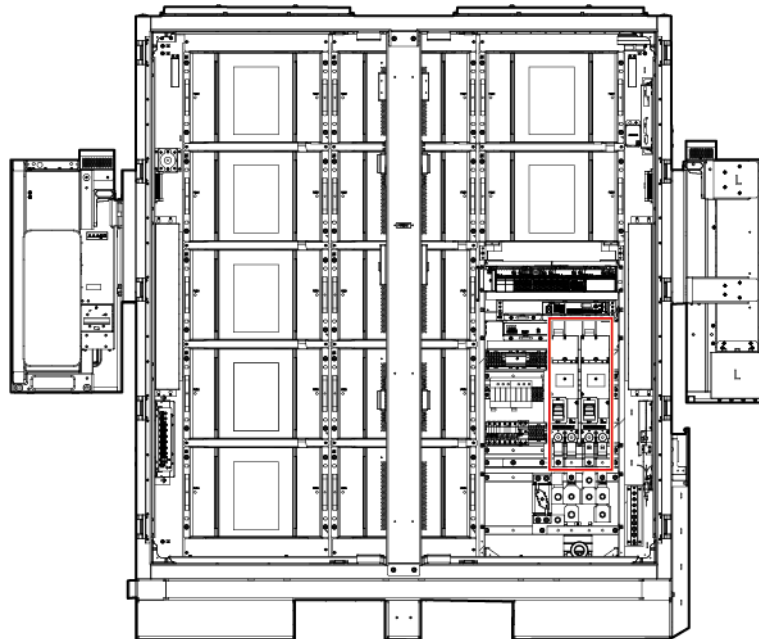

Prerequisites

- Fault locating:

Symptom	Possible Cause	Solution
The switch is faulty due to overcurrent or short circuit.	<ol style="list-style-type: none">1. The switch is not ON or OFF.2. The switch is faulty.	<ol style="list-style-type: none">1. Set the switch to OFF and then to ON.2. Replace the switch.

- Tools: Phillips insulated torque screwdriver, hex key
- Power off the ESS. For details, see [2.2 Powering Off a Single ESS](#).
- At least two persons are required to replace the component.

Procedure

Step 1 Remove the cover from the power distribution area.

Step 2 Remove the DC switch.

Figure 13-2 Removing the DC switch

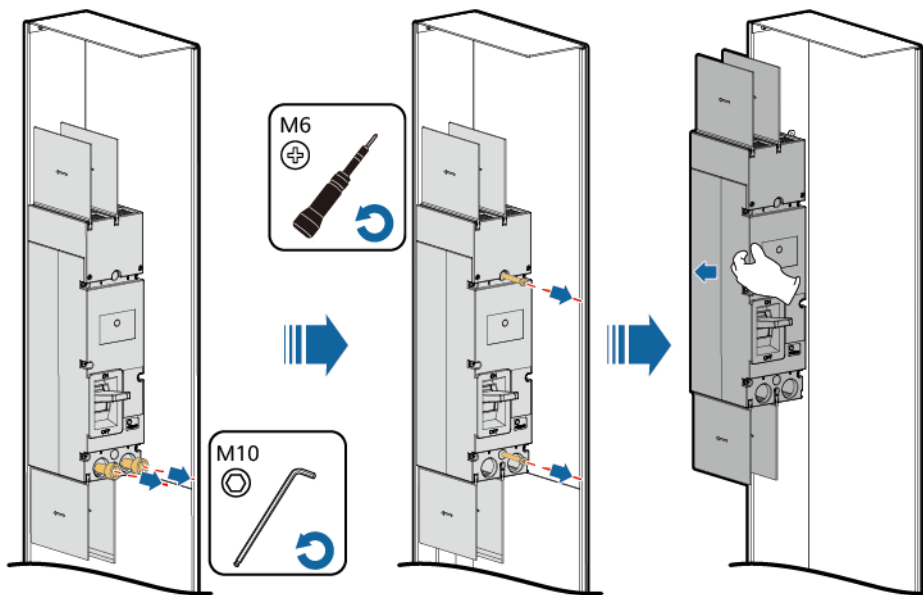

NOTE

Insulate the removed cables and copper bars.

Step 3 Install a new DC switch.

Figure 13-3 Installing a DC switch

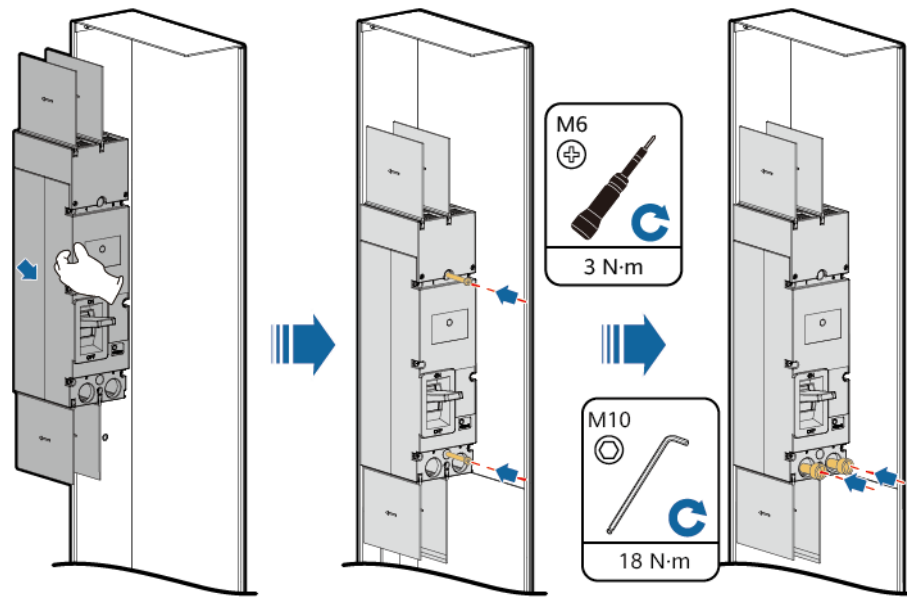

Step 4 Reinstall the cover.

----End

Follow-up Procedure

Step 1 Power on the system. For details, see the power-on section in the ESS user manual.

Step 2 Check the running status of the system and ensure that the functions are restored.

----End

13.2 Replacing an AC Main Switch

Figure 13-4 Position of the AC main switch

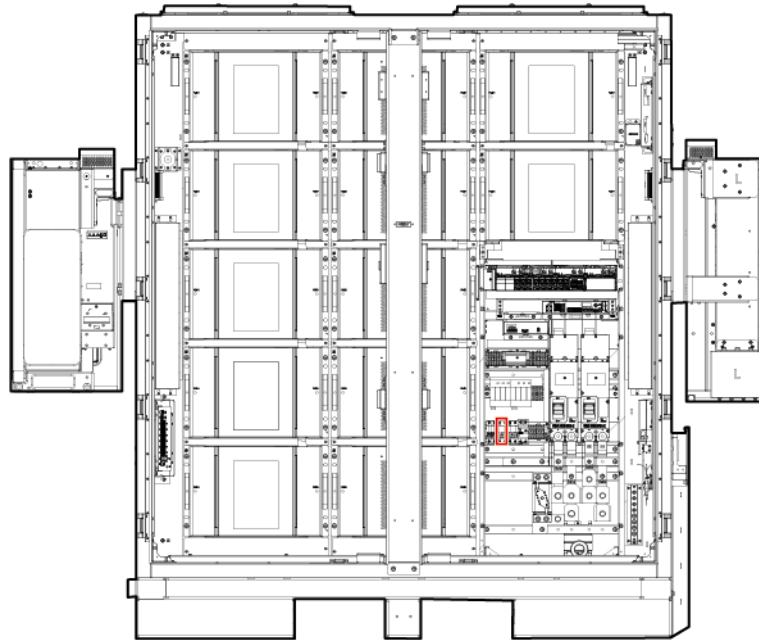

Step 1 Disconnect cables from the AC main switch and label the cables.

Step 2 Remove the faulty AC main switch.

Step 3 Install a new AC main switch.

Step 4 Connect the cables based on the labels.

----End

13.3 Replacing a 220 V Socket Switch

Figure 13-5 Position of the switch

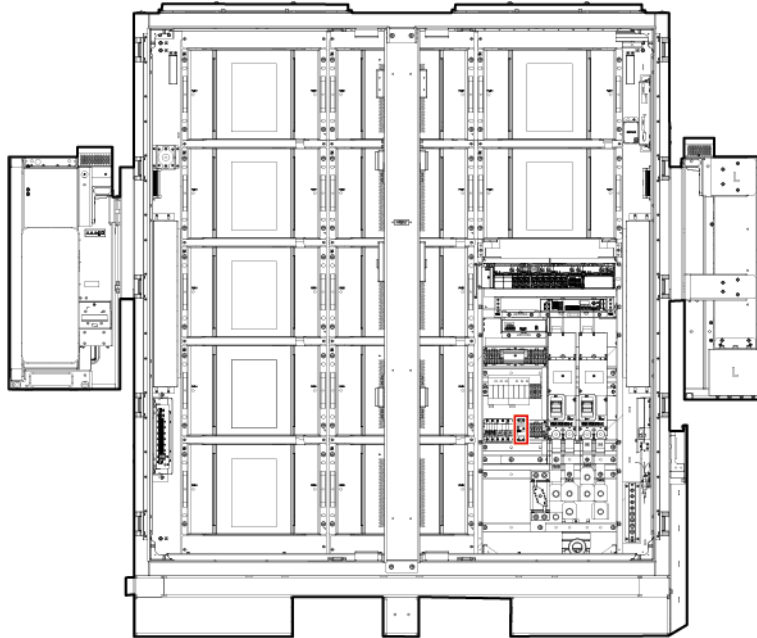

Step 1 Disconnect cables from the 220 V socket switch and label the cables.

Step 2 Remove the faulty 220 V socket switch.

Step 3 Install a new 220 V socket switch.

Step 4 Connect the cables based on the labels.

----End

13.4 Replacing a PSU Switch

Figure 13-6 Position of the switch

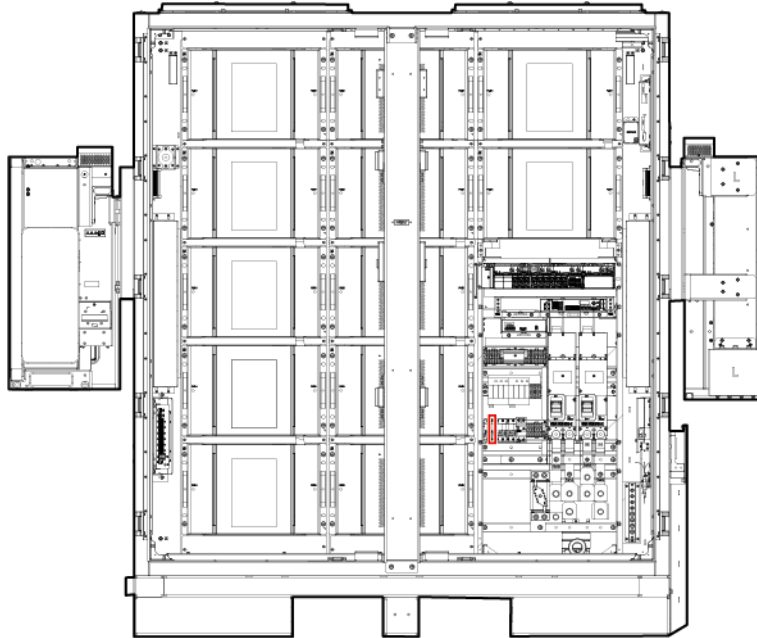

Step 1 Disconnect cables from the PSU switch and label the cables.

Step 2 Remove the faulty PSU switch.

Step 3 Install a new PSU switch.

Step 4 Connect the cables based on the labels.

----End

13.5 Replacing a UPS Switch

Figure 13-7 Position of the switch

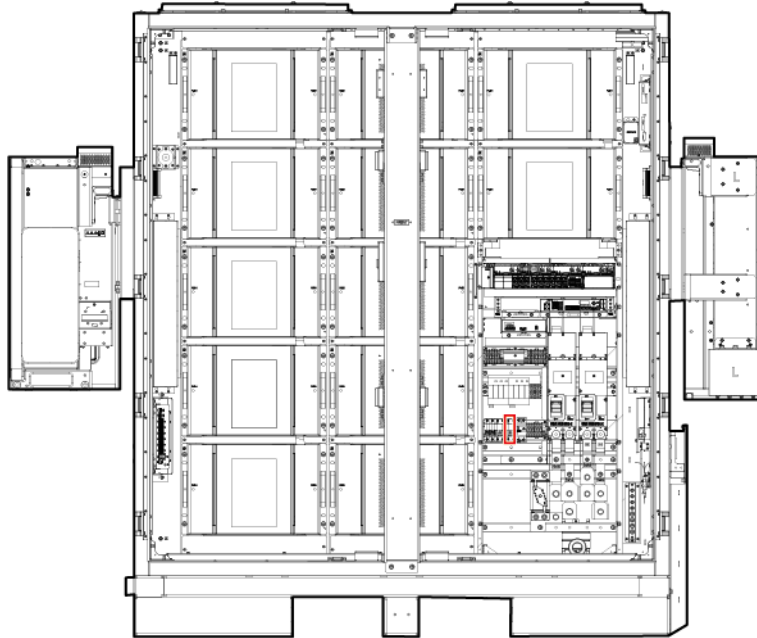

Step 1 Disconnect cables from the UPS switch and label the cables.

Step 2 Remove the faulty UPS switch.

Step 3 Install a new UPS switch.

Step 4 Connect the cables based on the labels.

----End

13.6 Replacing a DC Power Distribution Switch

Figure 13-8 Position of the switch

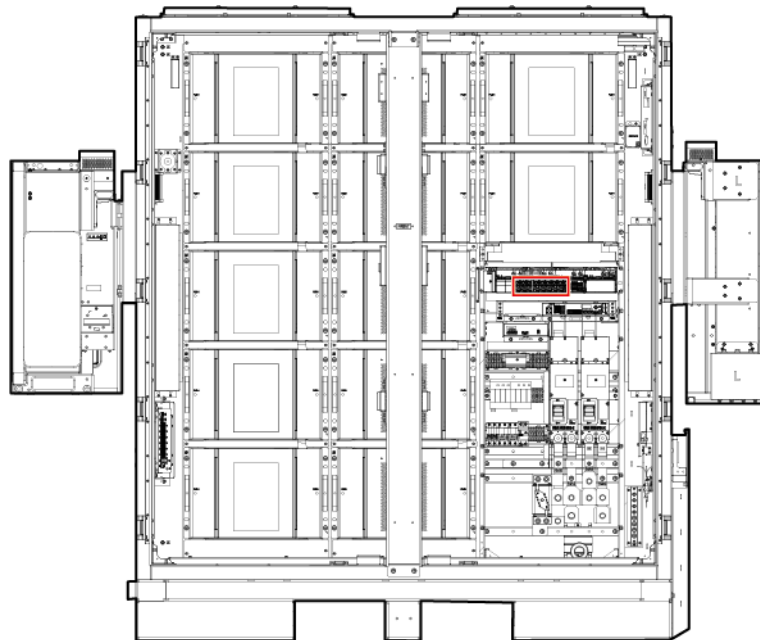

 **NOTE**

At least two persons are required to replace the component.

- Step 1** Disconnect the cables from the DC power distribution switch, and label the cables.
- Step 2** Remove the faulty DC power distribution switch.
- Step 3** Install a new DC power distribution switch.
- Step 4** Connect the cables based on the labels.

----End

14 Replacing an SPD

Prerequisites

Figure 14-1 Position of the SPD

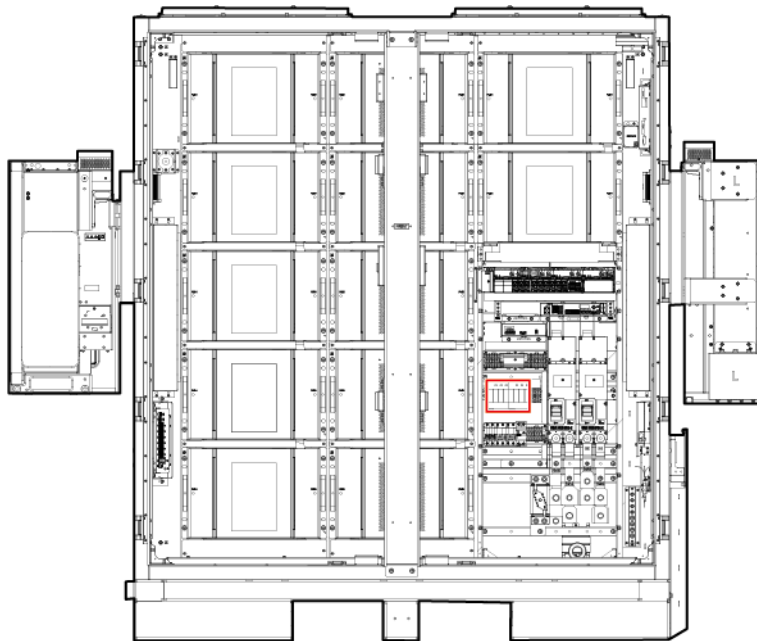

- Fault locating: If an SPD is damaged or its indication window is displayed in red, the SPD is faulty and needs to be replaced.
- Tools: ESD wrist strap or gloves, ESD box or bag, cabinet door key, removal and insertion tool
- Power off the ESS. For details, see [2.2 Powering Off a Single ESS](#).

⚠ DANGER

Do not replace an SPD during a thunderstorm.

Procedure

- Step 1** Remove the faulty surge protection module from the SPD.
- Step 2** Install a new surge protection module.

Figure 14-2 Replacing a surge protection module

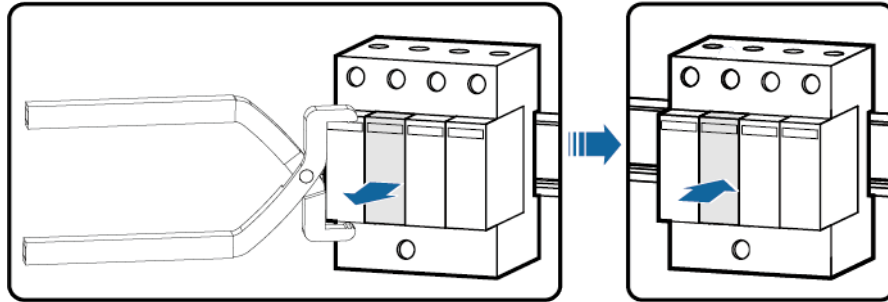

----End

Follow-up Procedure

Check that the SPD alarm is cleared.

15 Replacing an Emergency Stop Switch

Prerequisites

Figure 15-1 Position of the emergency stop switch

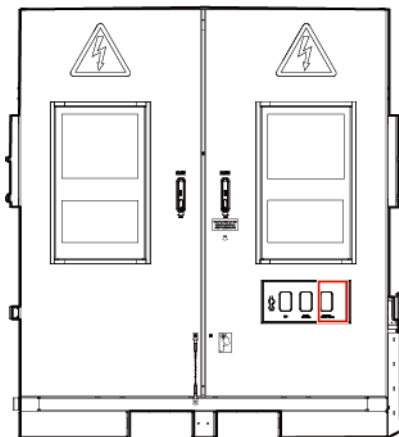

- Fault locating:
 - a. Log in to the SmartLogger WebUI, CMU WebUI, FusionSolar app, or management system to view alarm information.
 - b. Refer to the alarm handling suggestions in the alarm list.
- Tool: Phillips insulated torque screwdriver
- Power off the ESS. For details, see [2.2 Powering Off a Single ESS](#).

Procedure

Step 1 Remove the screws from the panel of the emergency stop button using a Phillips insulated torque screwdriver.

Step 2 Record the cable information, disconnect the cables from the emergency stop button, and remove the emergency stop button.

Step 3 Install a new emergency stop button in the same way.

----End

Follow-up Procedure

Step 1 Power on the system. For details, see the power-on section in the ESS user manual.

Step 2 Check the running status of the system and ensure that the functions are restored.

----End

16 Replacing an Embedded Power Subrack

Prerequisites

Figure 16-1 Position of the embedded power subrack

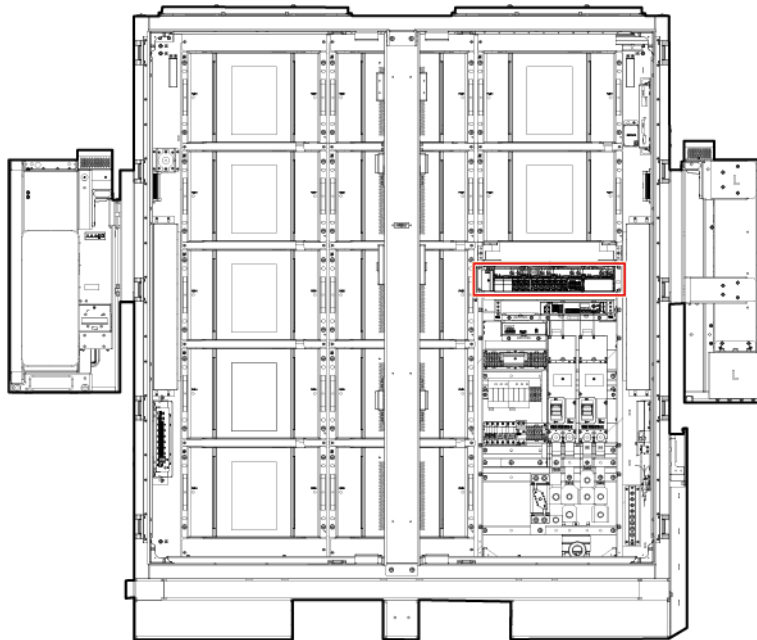

- Tool: Phillips insulated torque screwdriver
- Power-off: Turn off the upstream AC input switch for the embedded power subrack in the cabinet.

Procedure

Step 1 Wear protective gloves.

Step 2 Record the cable connection positions on the embedded power subrack and disconnect the cables.

- Step 3** Remove the old embedded power subrack.
 - Step 4** Install a new embedded power subrack.
 - Step 5** Remove the components from the old embedded power subrack and install them on the new embedded power subrack.
 - Step 6** Reconnect the cables to the new embedded power subrack based on the recorded information.
 - Step 7** Remove the protective gloves.
- End

17 Replacing a CMU Adapter

Prerequisites

Figure 17-1 Position of the CMU adapter

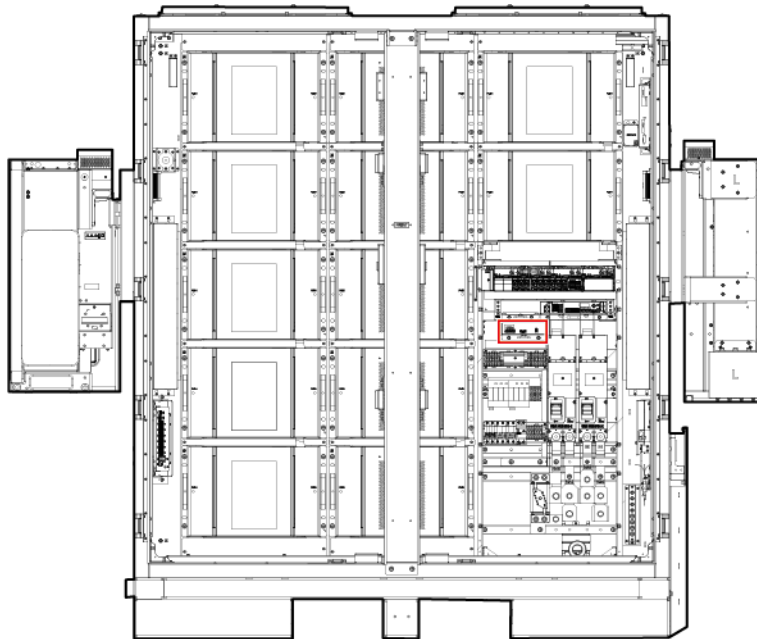

- Fault locating:
 - a. Check the fault indicator.

Status	Color	Indicat or Status	Description
The power module is normal.	Green	Steady on	The power input and output are normal, and the power module is running properly.

Status	Color	Indicat or Status	Description
The power module has no output.	Off	Off	The power module is faulty or has no output.
The power module is in hiccup protection mode.	Green	Blinking	The power module is in hiccup protection mode.

- b. Log in to the SmartLogger WebUI, CMU WebUI, FusionSolar app, or management system to view alarm information.
 - c. Refer to the alarm handling suggestions in the alarm list.
- Tool: Phillips insulated torque screwdriver
 - Power-off: Turn off AC switch 1FCB1 of the CMU adapter power supply.

Procedure

Step 1 Disconnect cables from the adapter and label them.

Step 2 Remove the faulty adapter and cabinet-mounting bracket.

Step 3 Install a new adapter in the cabinet.

Step 4 Connect the cables based on the labels.

----End

Follow-up Procedure

Step 1 Turn on AC switch 1FCB1 of the CMU adapter power supply.

Step 2 Log in to the SmartLogger WebUI, CMU WebUI, FusionSolar app, or management system and check that the communication is normal and that door status alarms are properly displayed.

Step 3 Check the indicator status and verify that the functions are restored.

----End

18 Replacing a CMU

Prerequisites

Figure 18-1 Position of the CMU

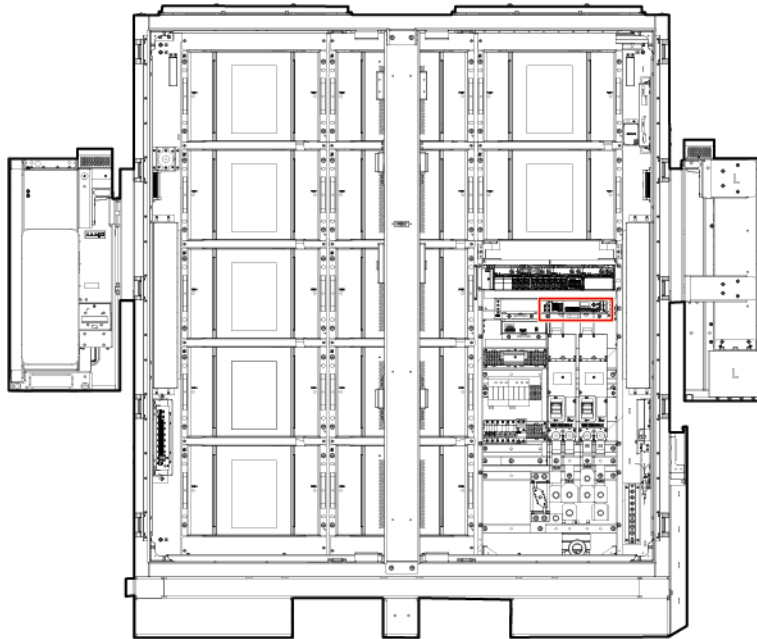

- Fault locating:
 - a. Log in to the SmartLogger WebUI, CMU WebUI, FusionSolar app, or management system to view alarm information.
 - b. Refer to the alarm handling suggestions in the alarm list.

- Exporting all configuration files:

 **NOTE**

If you cannot log in to the CMU because the CMU is damaged, skip this step. Set parameters after replacement.

- a. Log in to the CMU, choose **Maintenance > System Maint.**, and export the configuration files of the old CMU.

 NOTE

In the **Re-authentication** dialog box, enter **Password of current user** and set **Encryption password of the exported file**.

Figure 18-2 Exporting all configuration files

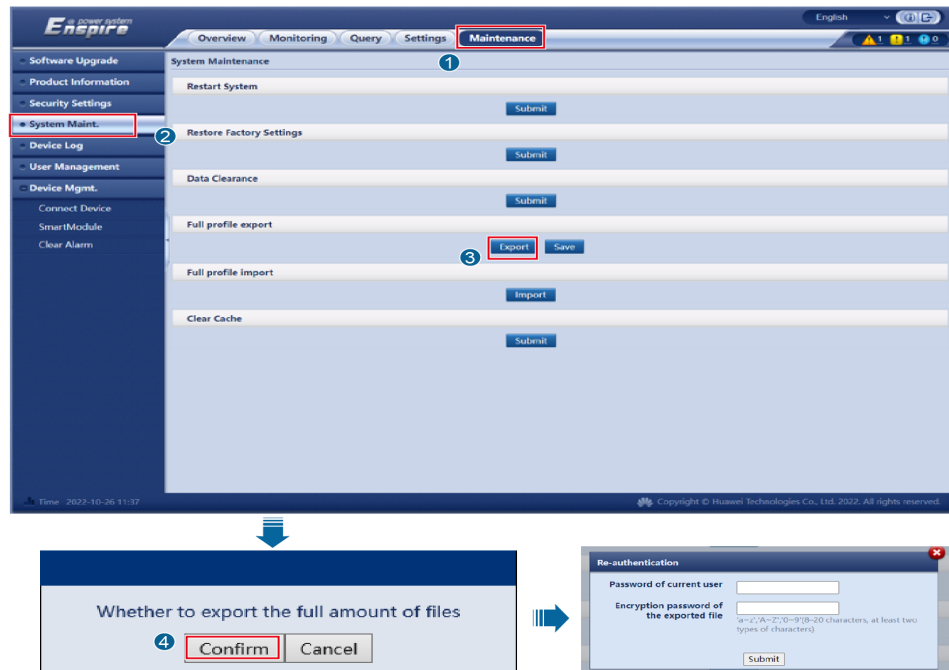

- b. After the export is successful, click **Confirm**. Click **Save** under **Full profile export** to save all configuration files.
- Tools: Phillips insulated torque screwdriver, insulated torque socket wrench
 - Power-off:
 - a. Log in to the SmartLogger WebUI, CMU WebUI, FusionSolar app, or management system and send a shutdown command to the rack controller.
 - b. Turn off the ESS output DC switch 1Q2.
 - c. Turn off the ESS battery rack DC switch 1Q1.
 - d. Turn off AC switch 1FCB1 of the CMU adapter power supply.
 - At least two persons are required to replace the component.

Procedure

Step 1 Disconnect cables from the CMU and label them.

Step 2 Remove the faulty CMU and its cabinet-mounting bracket.

Figure 18-3 Removing the faulty CMU

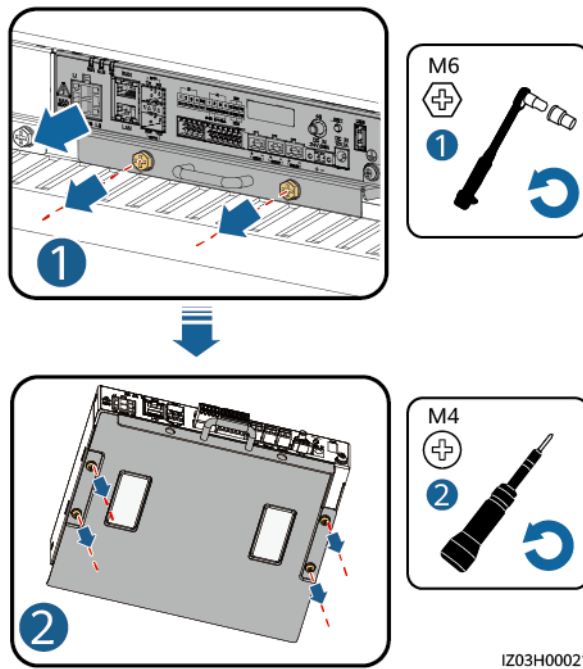

Step 3 Remove the mounting ears and guide rail-mounting brackets from a new CMU, and install the cabinet-mounting bracket.

Figure 18-4 Replacing a CMU

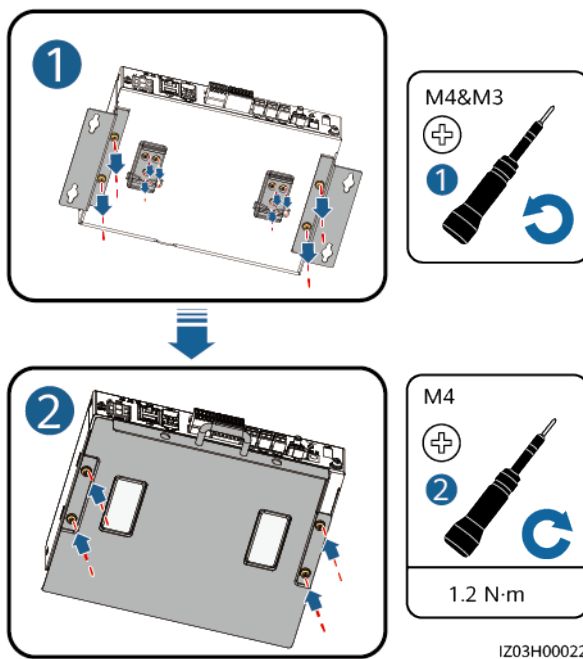

Step 4 Install the new CMU in the cabinet.

Step 5 Connect the cables based on the labels.

----End

Follow-up Procedure

- Step 1** Turn on AC switch 1FCB1 of the CMU adapter power supply.
- Step 2** Turn on DC switches 1Q1 and 1Q2 of the ESS.
- Step 3** Log in to the SmartLogger WebUI, CMU WebUI, FusionSolar app, or management system and check that the communication is normal and that no related alarm is generated.
- Step 4** Log in to the SmartLogger WebUI, CMU WebUI, FusionSolar app, or management system and send a startup command to the rack controller.
- Step 5** Check the running status of the system and ensure that the functions are restored.
- Step 6** (Optional) If all configuration files are exported before device replacement, log in to the CMU WebUI and import the exported configuration files to the new device. Otherwise, skip this step.

1. Choose **Maintenance > System Maint.**, and click **Import** under **Full profile import**

NOTE

In the **Re-authentication** dialog box, enter **Password of current user** and set **Decryption password of the imported file**.

NOTICE

In the CMU replacement scenario, certificate-related files are not exported among all configuration files. After all configuration files are imported, you need to reload a third-party certificate if needed.

Figure 18-5 Importing all configuration files

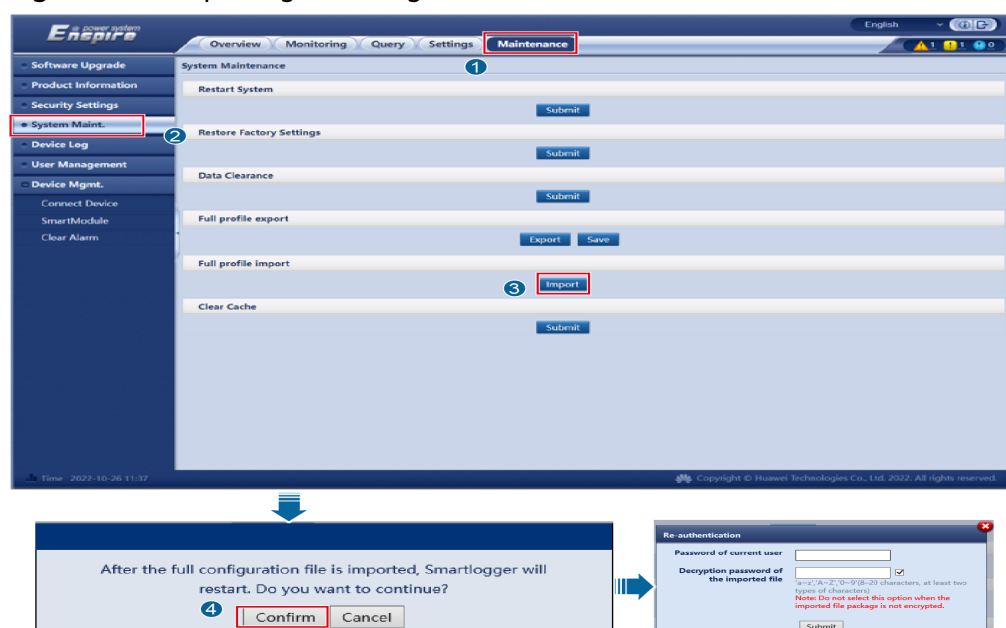

2. Click **Select File**, select the exported all configuration files, and then click **Import**.

Step 7 (Optional) If all configuration files are not exported before the device replacement, set the CMU parameters.

1. Log in to the CMU and choose **Maintenance > Device Mgmt. > Connect Device > Add Devices** to add a power meter, SMU, CO sensor, T/H sensor, and exhaust controller.

Table 18-1 Parameter settings

Device	Connection Mode/Port Number	Address
Power meter	COM1	11
SMU	COM2	33
CO sensor 1 ^a	COM3	1
CO sensor 2 ^a	COM3	15
T/H sensor	COM3	56
Exhaust controller	COM2	38

Note a: CO sensor 1 is on the left, and CO sensor 2 is on the right. For the specific positions, see [Figure 23-1](#).

Figure 18-6 Adding a device

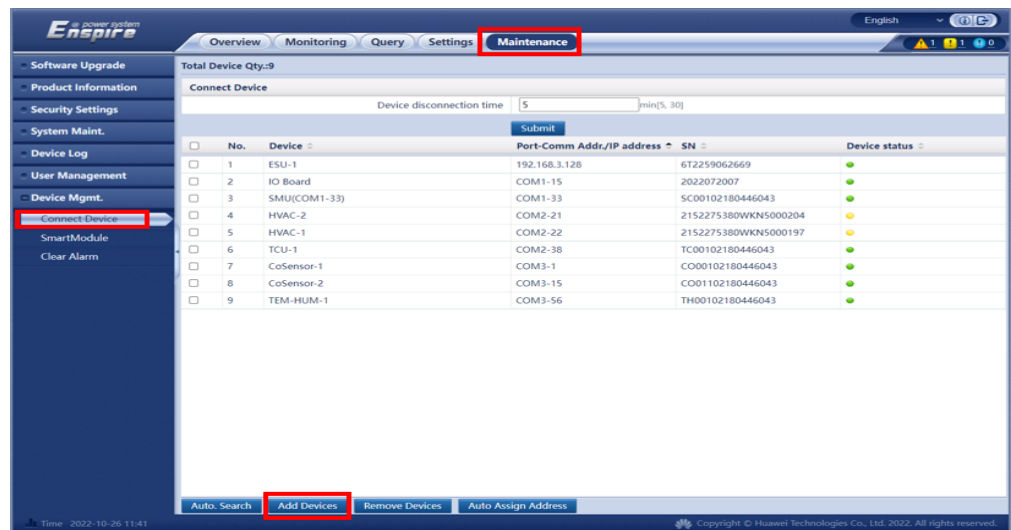

2. Click **Auto Assign Address**, select **Adjust Address**, and search and add the air conditioner again.
3. Click **Monitoring** to check whether the battery rack has been connected.

----End

19 Replacing a Door Status Sensor

Prerequisites

Figure 19-1 Positions of door status sensors

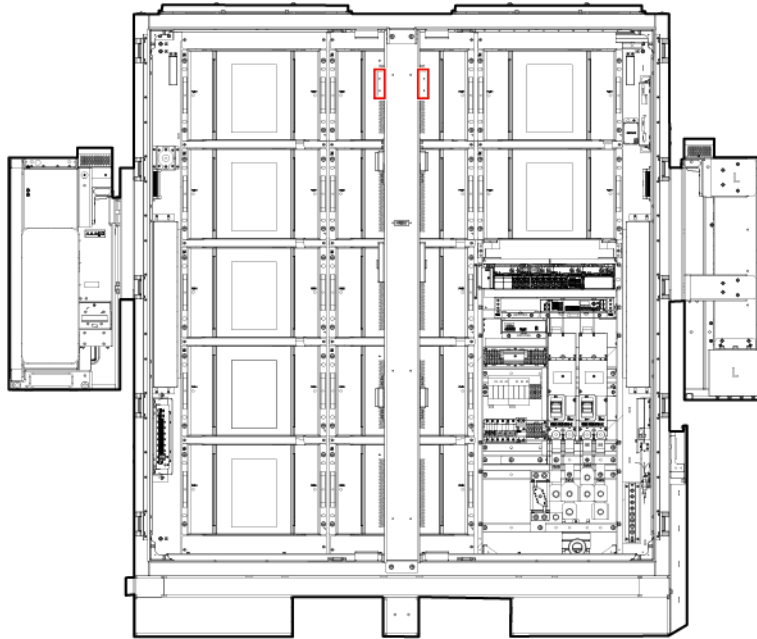

- The new door status sensor is intact.
- Tool: Phillips insulated torque screwdriver

Procedure

- Step 1** Remove the enclosure of the door status sensor.
- Step 2** Unscrew and remove the alarm cables and mark the connection positions.
- Step 3** Unscrew and remove the door status sensor.

Figure 19-2 Removing the door status sensor

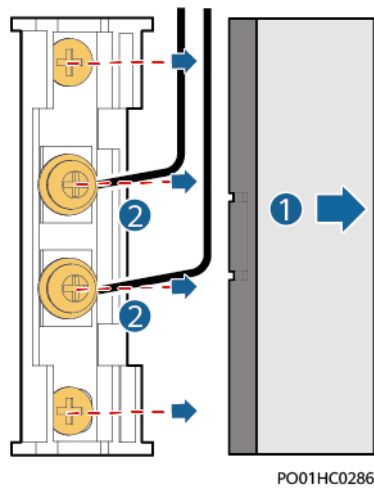

- Step 4** Remove the enclosure of the new sensor, and then remove the screws from the alarm cables.
- Step 5** Place the new door status sensor to the installation position and tighten the screws.
- Step 6** Connect the alarm cables in sequence and tighten the screws.
- Step 7** Reinstall the enclosure of the door status sensor.

----End

Follow-up Procedure

Check that the door status alarm is cleared.

20 Replacing a Water Sensor

Prerequisites

Figure 20-1 Position of the water sensor

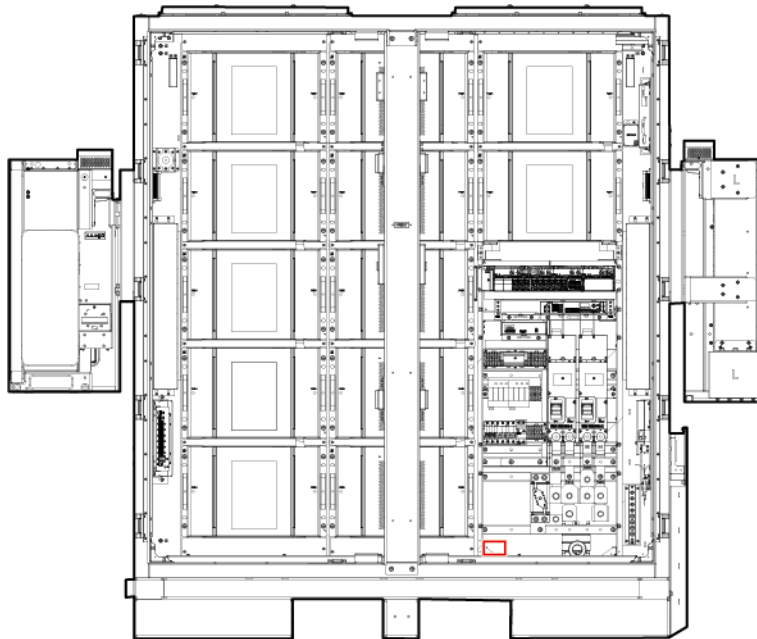

Tools: Phillips insulated torque screwdriver, torque wrench

Procedure

- Step 1** Remove cables from the water sensor.
- Step 2** Remove the faulty water sensor.

Figure 20-2 Removing the water sensor

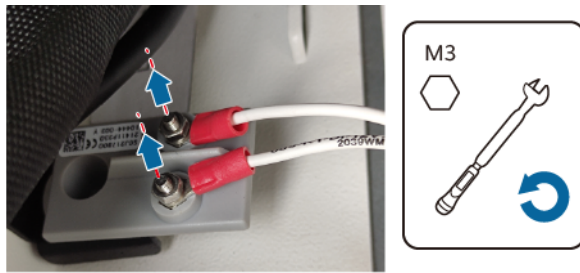

Step 3 Install a new water sensor.

Step 4 Connect the cables.

----End

21 Replacing a T/H Sensor

Prerequisites

Fault locating:

1. Log in to the SmartLogger WebUI, CMU WebUI, FusionSolar app, or management system to view alarm information.
2. Refer to the alarm handling suggestions in the alarm list.

Figure 21-1 Position of the T/H sensor

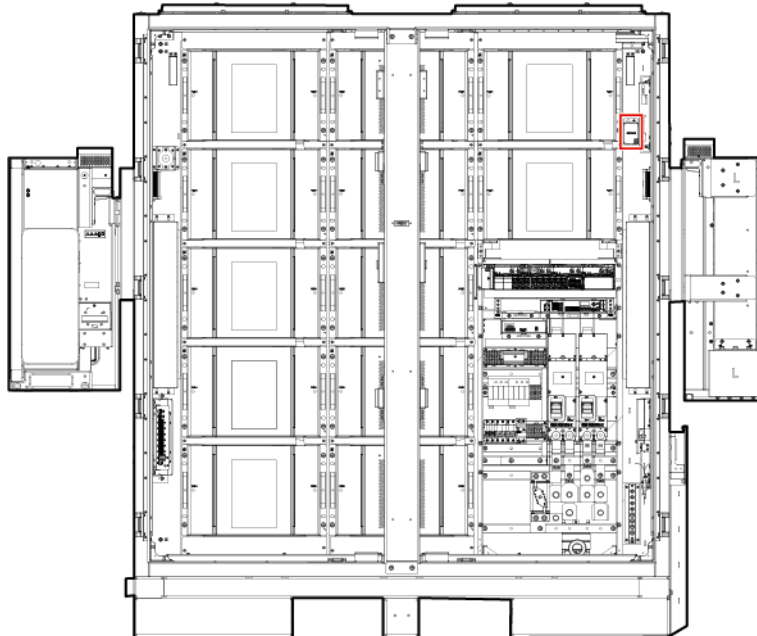

Procedure

- Step 1** Record the DIP switch settings.

Table 21-1 DIP switch settings

T/H Sensor Address	Toggle Switch 1	Toggle Switch 2	Toggle Switch 3	Toggle Switch 4	Toggle Switch 5	Toggle Switch 6
56	OFF	OFF	OFF	ON	ON	ON

Step 2 Disconnect cables from the T/H sensor.

Step 3 Removing the faulty T/H sensor.

Step 4 Set the DIP switches for a new T/H sensor based on the recorded information.

Step 5 Install the new T/H sensor.

Step 6 Connect the cables.

Step 7 Check that no alarm is generated.

----End

22 Replacing an Exhaust Controller

Prerequisites

- Tool: Phillips insulated torque screwdriver
- Power off the ESS. For details, see [2.2 Powering Off a Single ESS](#).

Figure 22-1 Position of the exhaust controller (TCUE)

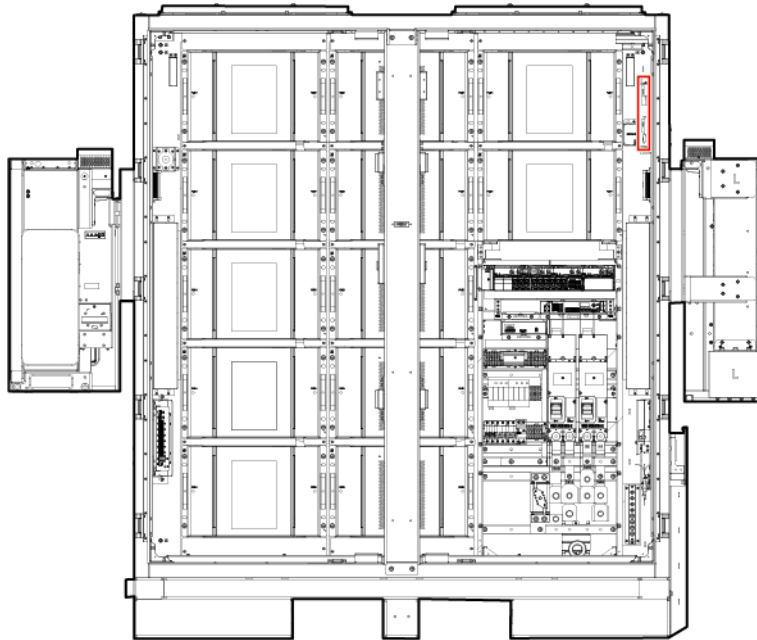

Procedure

- Step 1** Disconnect the upstream power input for the TCUE.
- Step 2** Record the cable connection positions on the TCUE, and disconnect the cables.
- Step 3** Remove the TCUE control box.

Figure 22-2 Removing the TCUE control box

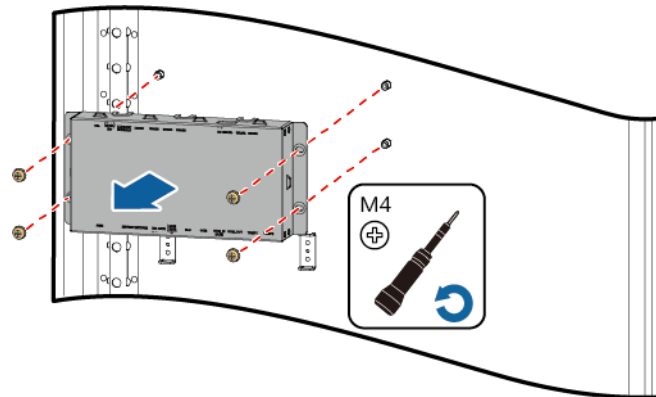

Step 4 Remove the old TCUE control board.

Figure 22-3 Removing the old TCUE control board

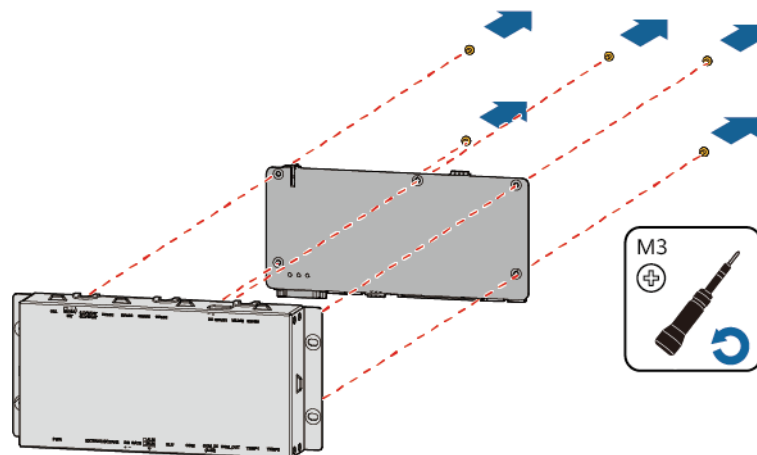

Step 5 Record the cable connection positions on the TCUE control board and disconnect the cables.

Step 6 Record the information about the jumper caps on the TCUE control board.

Figure 22-4 Positions of the jumpers on the TCUE control board

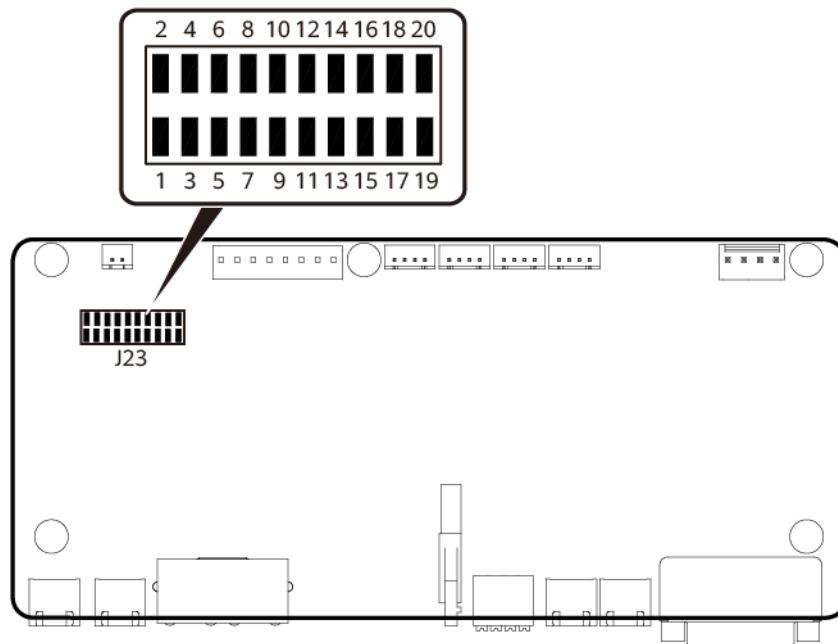

- Step 7** Adjust the positions of the jumper caps on the new TCUE control board based on the recorded information.
- Step 8** Connect cables to the new TCUE control board based on the recorded information.
- Step 9** Install the new TCUE control board to the TCUE control box.

Figure 22-5 Installing the new TCUE control board

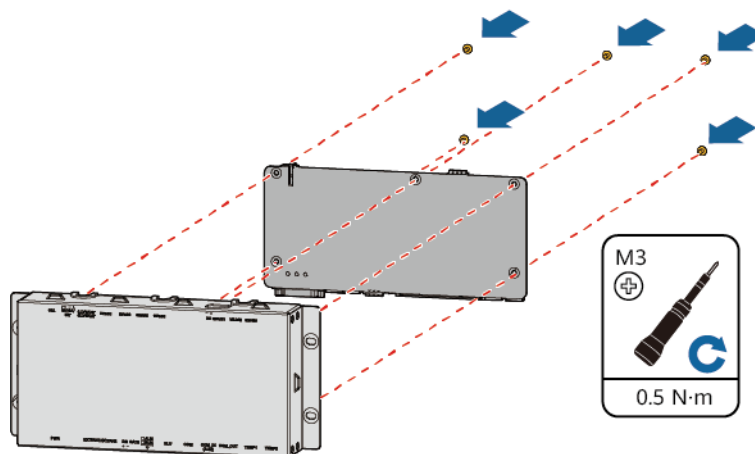

- Step 10** Reinstall the TCUE control box.

Figure 22-6 Reinstalling the TCUE control box

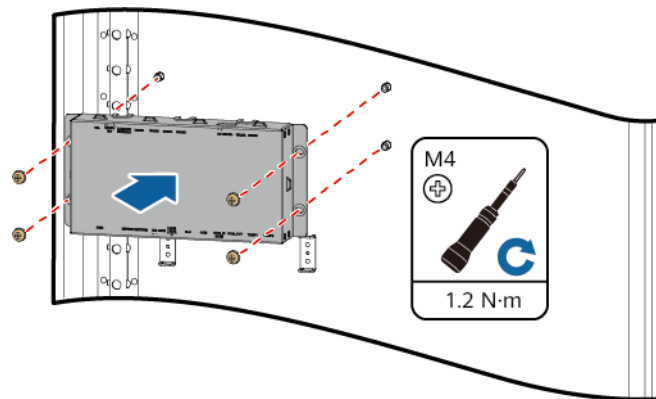

Step 11 Connect cables to the TCUE control box based on the recorded information.

Step 12 Connect the upstream power input for the TCUE.

----End

23 Replacing a CO Sensor

Figure 23-1 Positions of CO sensors

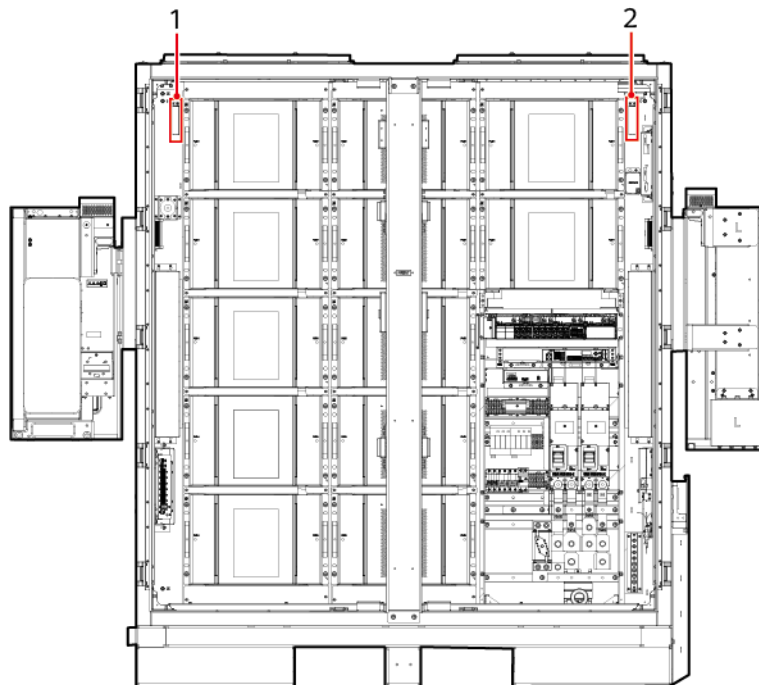

Procedure

Step 1 Record the DIP switch settings.

Table 23-1 DIP switch settings

Position (See Figure 23-1)	CO Sensor Address	Toggle Switch 1	Toggle Switch 2	Toggle Switch 3	Toggle Switch 4
1	1	ON	OFF	OFF	OFF
2	15	ON	ON	ON	ON

Step 2 Remove cables from the CO sensor.

Step 3 Remove the faulty CO sensor.

Step 4 Set the DIP switches for a new CO sensor based on the recorded information.

Step 5 Install the new CO sensor.

Step 6 Connect the cables.

Step 7 Check that no alarm is generated.

----End

24 Replacing an Exhaust Fan

Prerequisites

Figure 24-1 Position of the exhaust fan

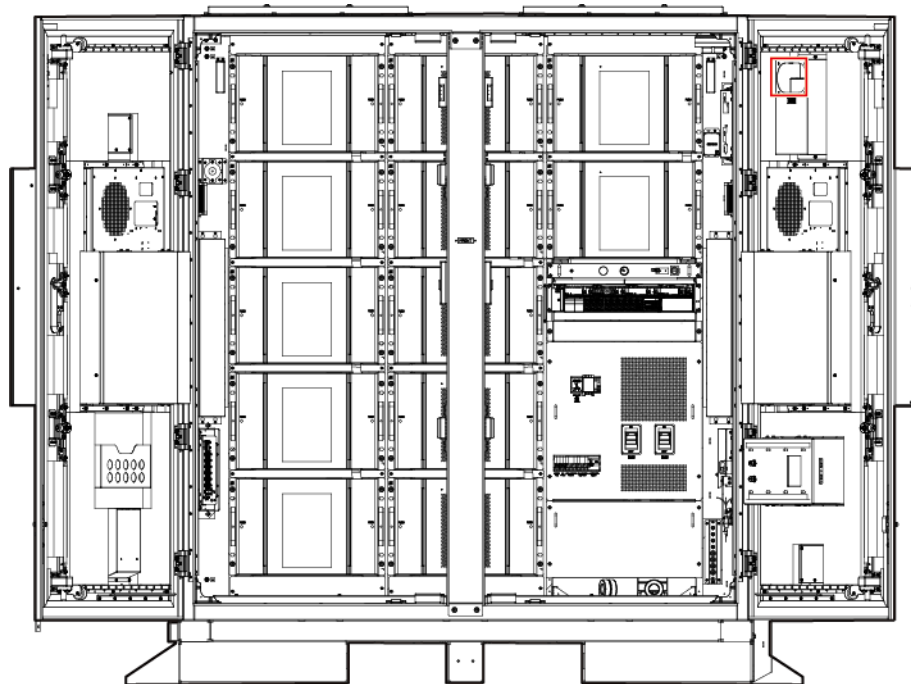

- Tool: flat-head or Phillips insulated torque screwdriver
- Power off the ESS. For details, see [2.2 Powering Off a Single ESS](#).

Procedure

- Step 1** Remove the fan baffle plate.
- Step 2** Disconnect cables between the fan and the terminals.
- Step 3** Unscrew and remove the exhaust fan.
- Step 4** Install a new fan and tighten the screws.

Step 5 Connect the cables between the fan and the terminals.

Step 6 Secure the fan baffle plate.

----**End**

25 Replacing an SMU11B

Prerequisites

Figure 25-1 Position of the SMU11B

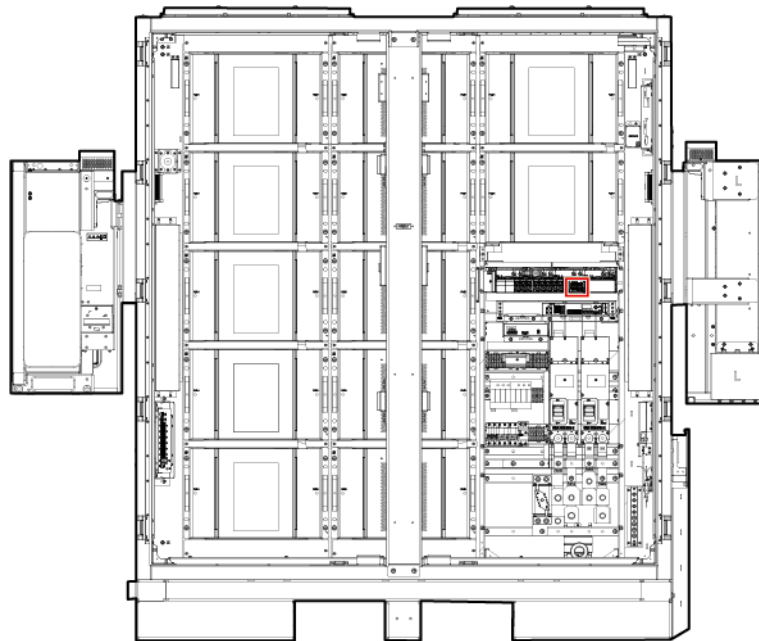

- Tools: ESD wrist strap, ESD gloves, ESD box or bag, tool box
- The new SMU is intact.

Procedure

- Step 1** Connect the ground cable of the ESD wrist strap, and wear the ESD wrist strap and ESD gloves.
- Step 2** Record the cable connection positions on the SMU panel, remove the COM communications cables, and remove the signal cable terminals.
- Step 3** Pull out the handle to remove the SMU from the subrack.

Figure 25-2 Removing the old SMU

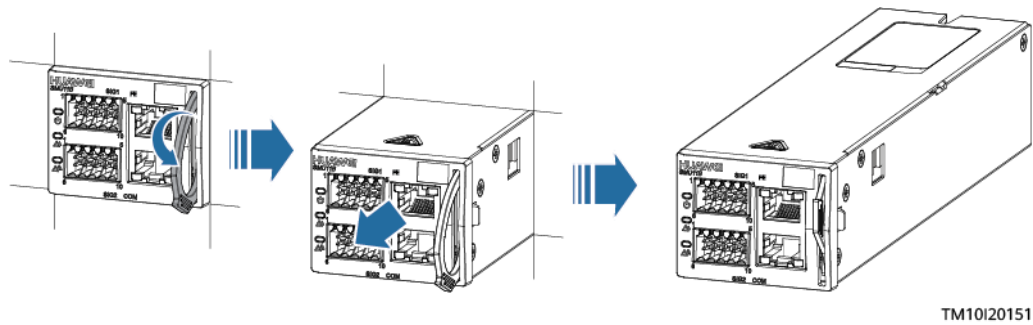

Step 4 Check the DIP switch settings of the SMU.

Step 5 Set the DIP switch on the new SMU based on the DIP switch settings.

Step 6 Insert the new SMU into the slot and slide it into the subrack along the guide rails.

Step 7 Push the handle of the SMU upwards until it is in position.

Figure 25-3 Installing the new SMU

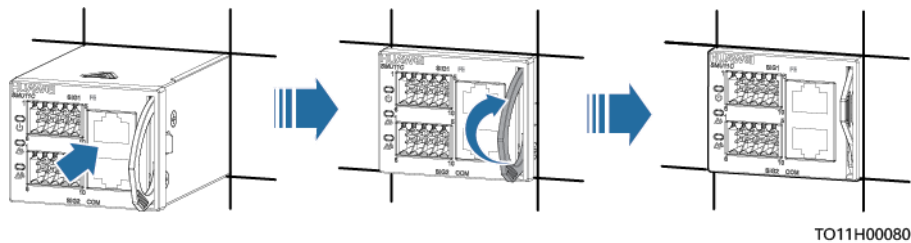

Step 8 Connect the signal cable terminals and COM communications cables to the panel of the new SMU based on the recorded information.

Step 9 Disconnect the ground cable of the ESD wrist strap, and remove the ESD wrist strap and ESD gloves.

----End

Follow-up Procedure

Put the removed component in an ESD box or bag and return it to the local warehouse.

26 Replacing a Smoke Detector

Figure 26-1 Position of the smoke detector

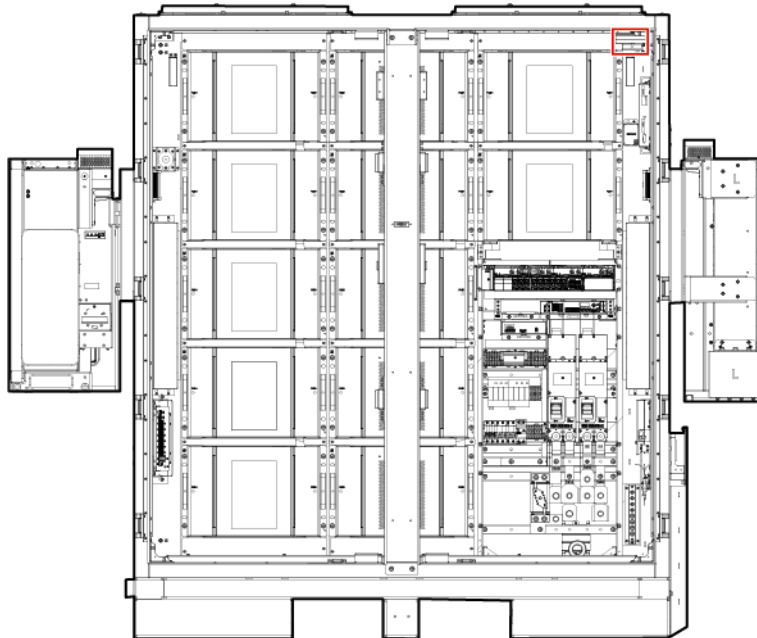

Step 1 Record the cable connection positions on the smoke detector and remove the cables.

Step 2 Hold the smoke detector by hand, and rotate it counterclockwise to remove it from the base.

Figure 26-2 Removing the smoke detector

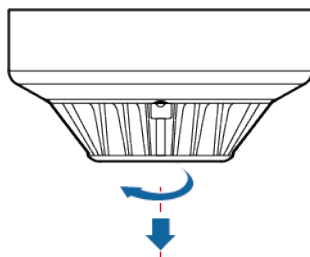

Step 3 Install a new smoke detector and rotate the detector clockwise until it locks into place.

Step 4 Reconnect the cables to the new smoke detector based on the recorded information.

----**End**

27 Replacing an I/O Expansion Board

Context

Figure 27-1 Position of the I/O expansion board

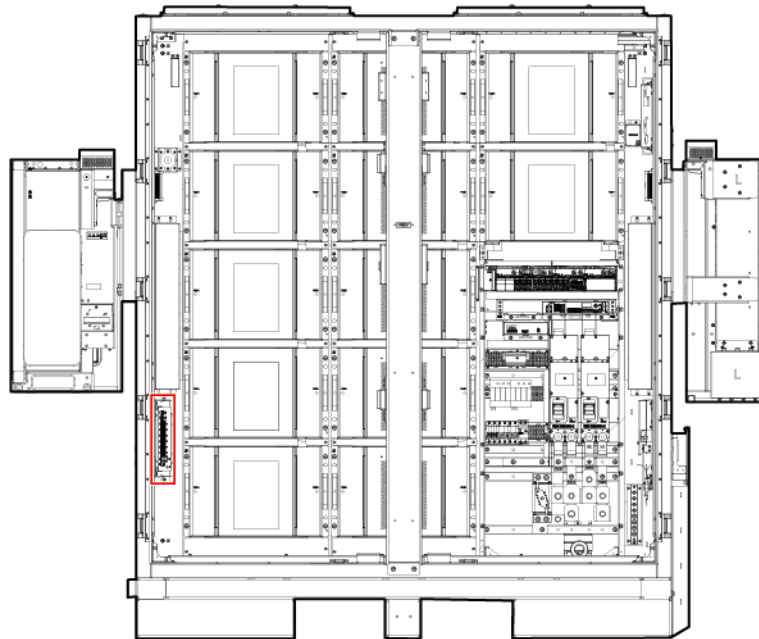

- Fault locating:
 - a. Log in to the SmartLogger WebUI, CMU WebUI, FusionSolar app, or management system to view alarm information.
 - b. Refer to the alarm handling suggestions in the alarm list.
- Tools: Phillips insulated torque screwdriver, insulated torque socket wrench
- Power-off:
 - a. Log in to the SmartLogger WebUI, CMU WebUI, FusionSolar app, or management system and send a shutdown command to the rack controller.
 - b. Turn off the ESS output DC switch 1Q2.
 - c. Turn off the ESS battery rack DC switch 1Q1.

- d. Turn off AC switch 1FCB1 of the CMU adapter power supply.

Procedure

Step 1 Disconnect cables from the CMU and label the cables.

Step 2 Remove the faulty I/O expansion board.

Figure 27-2 Removing the I/O expansion board

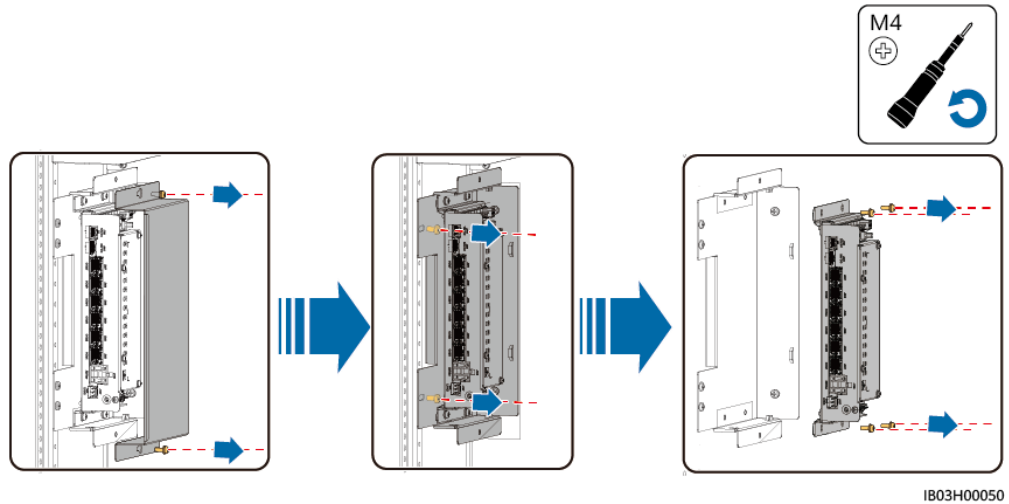

Step 3 Install a new I/O expansion board.

Figure 27-3 Installing an I/O expansion board

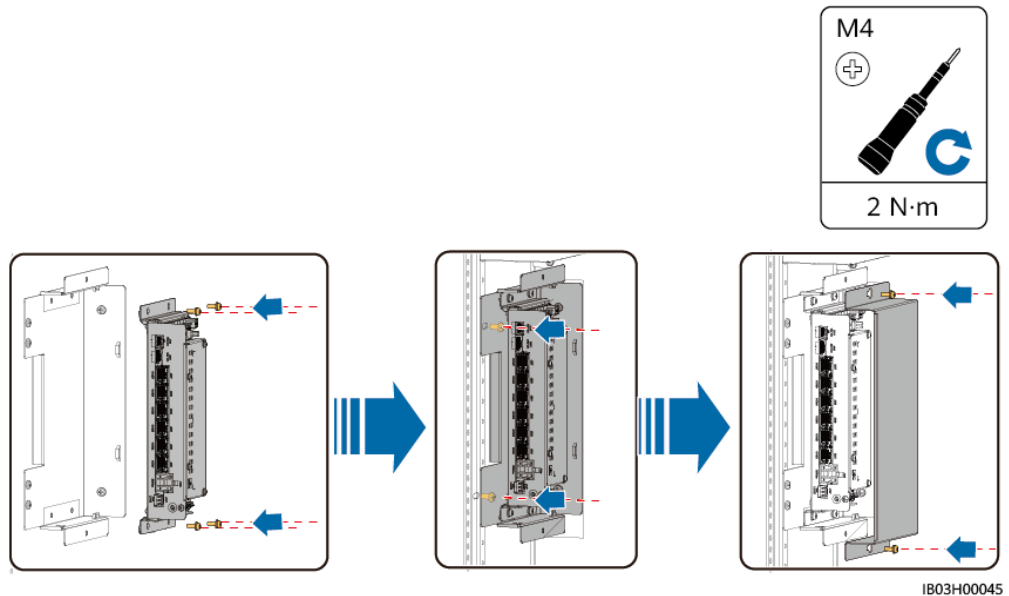

Step 4 Reinstall the cables.

----End

Follow-up Procedure

- Step 1** Turn on AC switch 1FCB1 of the CMU adapter power supply.
- Step 2** Turn on DC switches 1Q1 and 1Q2 of the ESS.
- Step 3** Log in to the SmartLogger WebUI, CMU WebUI, FusionSolar app, or management system and check that the communication is normal and that no related alarm is generated.
- Step 4** Log in to the SmartLogger WebUI, CMU WebUI, FusionSolar app, or management system and send a startup command to the rack controller.
- Step 5** Check the running status of the system and ensure that the functions are restored.
- Step 6** Log in to the CMU WebUI, choose **Maintenance > Device Mgmt. > Connect Device > Auto. Search**, and connect the I/O expansion board.

----End

28 Emergency Handling

If an accident (including but not limited to the following) occurs on the site, ensure the safety of onsite personnel first and contact the Company's service engineers.

Battery Falling or Strong Impact

- If a battery has obvious damage or abnormal odor, smoke, or fire occurs, evacuate the personnel immediately, call emergency services, and contact the professionals. The professionals shall use fire extinguishing facilities to extinguish the fire under safety protection.
- If the appearance is not deformed or damaged, and there is no obvious abnormal odor, smoke, or fire, ensure safety and perform the following operations:
 - Warehouse: Evacuate personnel, transfer the battery to an open and safe place by professionals using mechanical tools, and contact the Company's service engineers. Leave the battery for an hour and ensure that the battery temperature is within the room temperature range (tolerance: $\pm 10^{\circ}\text{C}$) before handling.
 - ESS onsite: Evacuate personnel, close the doors of the ESS, transfer the battery to an open and safe place by professionals using mechanical tools, and contact the Company's service engineers. Leave the battery for an hour before handling.

Flood

- Power off the system if it is safe to do so.
- If any part of the batteries is submerged in water, do not touch the batteries to avoid electric shock.
- Do not use batteries that have been soaked in water. Contact a battery recycling company for disposal.

Fire

 **DANGER**

- If a fire occurs, power off the system if it is safe to do so.
 - Extinguish the fire with carbon dioxide, FM-200 or ABC dry powder fire extinguishers.
 - Ask firefighters to avoid contact with high-voltage components during fire fighting to prevent the risk of electric shock.
 - Overheating may cause battery deformation, faults, and leakage of corrosive electrolytes or toxic gases. Use respiratory protective equipment and keep a safe distance from the batteries to prevent skin irritation and chemical burns.
-

Fire Alarm Horn/Strobe

When the alarm indicator on the equipment blinks or buzzes:

- Do not approach.
- Do not open the door.
- Stay away immediately.
- Cut off the power supply remotely only when your safety is guaranteed.

Gas Exhaust

- Onsite personal protection: Do not directly face the exhaust vents.
- Post-disaster product maintenance: Contact the Company's service engineers for evaluation.

Extinguishant Release or Fire

- Suggestions for onsite O&M personnel:
 - a. When a fire occurs, evacuate from the building or equipment area, press the fire alarm bell, and immediately call the fire emergency service. Notify the professional firefighters and provide them with relevant product information, including but not limited to battery pack types, ESS capacity, and battery pack location and distribution.
 - b. Do not enter the affected building or equipment area under any circumstances, and do not open the doors of the ESS. Isolate and monitor the site. Keep irrelevant personnel away from the site.
 - c. After calling the fire emergency service, remotely power off the system (such as the Smart Transformer Station, Smart PCS, auxiliary power supply devices, and combiner box power supply) while ensuring your own safety.
 - d. After professional firefighters arrive, provide relevant product information, including but not limited to battery pack types, ESS capacity, battery pack location and distribution, and user manuals.
 - e. After the fire is extinguished, the site must be handled by professionals in accordance with local laws and regulations. Do not open the doors of the ESS without permission.

- f. Post-disaster product maintenance: Contact the Company's service engineers for evaluation.
- Suggestions for professional firefighters:
 - a. For product information, see the information provided by O&M personnel, including but not limited to battery pack types, ESS capacity, battery pack location and distribution, and user manuals.
 - b. Do not open the doors of the ESS before it is deemed safe by professionals.
 - c. Follow local fire fighting regulations.

29 FAQ

29.1 How Do I Recycle Used Batteries?

NOTICE

- The Company does not recycle batteries. Contact local recycling agencies to handle batteries.
- If there are no such agencies in your area, you can contact the nearest foreign recycling agencies.

Step 1 Contact the nearest recycling agency.

Step 2 Recycling agencies assess the costs.

Step 3 Recycling agencies carry out recycling, which can be done in two ways:

- Onsite recycling: Recycling agencies can visit your sites to recycle lithium batteries, but the price depends on actual conditions such as the distance and transportation expenses.
- Centralized recycling: You can collect all lithium batteries to be recycled in one place for the recycling agencies to handle.

NOTE

You need to cover the related transportation expenses.

Step 4 Recycling companies handle recycling. The recycled lithium batteries are at the disposal of the recycling companies.

----End

29.2 How Do I Repair Paint Damage?

Prerequisites

- Do not apply paint in bad weather, such as rain, snow, strong wind, and sandstorm, when there is no shelter outdoors.
- You have prepared the required paint that matches the color palette delivered with equipment.

Paint Repair Description

The equipment appearance should be intact. If paint has flaked off, repair paint damage immediately.

NOTE

Check the paint damage on the equipment and prepare appropriate tools and materials. The number of materials depends on site requirements.

Table 29-1 Paint repair description

Paint Damage	Tool and Material	Procedure	Description
Slight scratch (steel base material not exposed)	Spray paint or paint, brush (required for repainting a small area), fine sandpaper, anhydrous alcohol, cotton cloth, and paint spray gun (required for repainting a large area)	Steps 1, 2, 4, and 5	<ol style="list-style-type: none"> 1. For the color of the finish coat (acrylic acid paint), see the delivered color palette and Pantone number specified on it. 2. For a few scratches, smudges, or rust, manual paint spraying or brushing is recommended.
Smudges and rust that cannot be removed			
Deep scratch (primer damaged, steel base material exposed)	Spray paint or paint, zinc-rich primer, brush (required for repainting a small area), fine sandpaper, anhydrous alcohol, cotton cloth, paint spray gun (required for repainting a large area)	Steps 1, 2, 3, 4, and 5	<ol style="list-style-type: none"> 3. For many scratches or large-area smudges and rusts, use a paint spray gun. 4. The paint coating should be thin and

Paint Damage	Tool and Material	Procedure	Description
Logo and pattern damage		If a logo or pattern is damaged, provide the logo size and color number. Seek help from a local supplier of advertisement coatings to formulate a repair solution based on the logo size, color, and damage.	even. Paint drops are prohibited on the coating. The surface should be smooth.
Dent		<ol style="list-style-type: none"> 1. If a dent is less than or equal to 100 mm² in area and less than 3 mm in depth, fill the dent with Poly-Putty base and then perform the same operations as those for processing deep scratches. 2. If a dent is greater than 100 mm² in area or greater than 3 mm in depth, ask the local supplier for an appropriate repainting solution. 	5. Leave the repainted area for approximately 30 minutes before performing any further operation.

Procedure

Step 1 Gently polish damaged areas using fine sandpaper to remove smudges or rust.

Figure 29-1 Polishing a damaged area using sandpaper

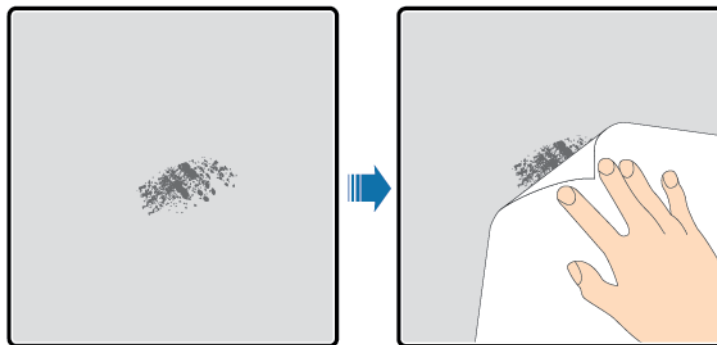

DM97000001

Step 2 Dip a piece of cotton cloth into anhydrous alcohol and wipe the polished or damaged area to remove the dirt and dust. Then wipe off the anhydrous alcohol with a clean and dry cotton cloth

Figure 29-2 Wiping a polished or damaged area using anhydrous alcohol

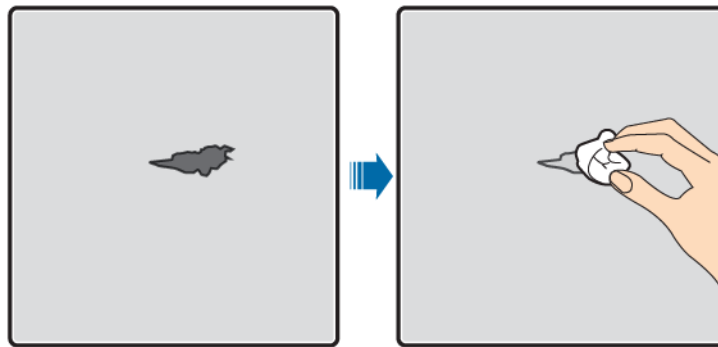

DD0000012

Step 3 Paint zinc-rich primer on the damaged coat using a brush or paint spray gun.

NOTICE

- If the base material is exposed in the area to be repaired, apply epoxy zinc-rich primer, wait until the paint has dried, and then apply acrylic acid top coat.
- Select epoxy zinc-rich primer or acrylic acid top coat with a color the same as the surface coating color of the equipment.

Step 4 Apply paint evenly to the damaged area based on the damage degree of the paint using an aerosol spray, brush, or paint spray gun until all damage traces are invisible.

NOTICE

- Ensure that the painting is thin, even, and smooth.
- In the case that an equipment pattern has different colors, to prevent undamaged areas and those with different colors as the damaged area from being contaminated during repainting, cover such areas using white paper and adhesive tape before repairing paint.

Figure 29-3 Repainting a damaged area

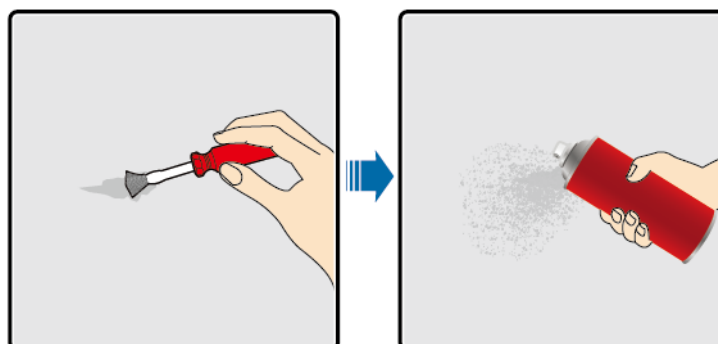

DD0000013

Step 5 Wait for 30 minutes and check whether the painting meets the requirements.

 **NOTE**

- The color of the repainted area must be consistent with that of the surrounding area. Use a colorimeter to measure the color difference, which should be less than or equal to 3 ($\Delta E \leq 3$). If a colorimeter is unavailable, ensure that there is no visible edge between the repainted area and the surrounding area. The paint should be free of bulges, scratches, flaking, or cracks.
- If you choose to spray paint, it is recommended that you spray paint three times before checking the result. If the color does not meet the requirements, paint more times until the painting meets the requirements.

----End

Paint Supply Information

Table 29-2 Paint requirements

Item	Requirement
Primer thickness	60 μm
Intermediate coat thickness	120 μm
Top coat thickness	60 μm
Primer type	Epoxy zinc-rich paint
Intermediate coat type	Zinc-rich paint
Color number of the top coat	Obtain the color number based on the color palette delivered with the product.

 **NOTE**

The following is a paint model list provided by Huawei. The list may be updated from time to time and is for reference only. The cost of paint and technical services is subject to the local pricing standards.

Supplier	Position	Paint Model
Hempel	Equipment surface painting	Zinc-rich primer for pretreatment: HEMPADUR ZINC (shopprimer) 1536C/19830 Zinc-rich primer for the entire container: HEMPADUR ZINC (on line) 1536C/19830 Intermediate coat: HEMPADUR FAST DRY 15560/12170 Top coat: HEMPADUR 55210/17630 (RAL9003)

Supplier	Position	Paint Model
	Logo	Red: HEMPATHANE 55210/57200 (RAL3020) Black: HEMPATHANE 55210-19990 (RAL9005)
CMP	Equipment surface painting	Zinc-rich primer for pretreatment: EPICON ZINC SC B-2 M (SHOP PRIMER) Zinc-rich primer for the entire container: EPICON ZINC SC B-2 M (ON LINE ZINC) Intermediate coat: EPICON SC PRIMER GREY CSC-9107 Top coat: UNYMARINE SC FINISH WHITE CSC-9205 (RAL-9003)
	Logo	Red: UNYMARINE SC MARKING RAL-3020 Black: UNYMARINE SC MARKING RAL-9005

29.3 Battery Pack Storage and Single Battery Pack Charge

Material Delivery Check

There must be a battery charge label on the packing case. The charge label must specify the latest charge time and the next charge time.

Figure 29-4 Battery charge label

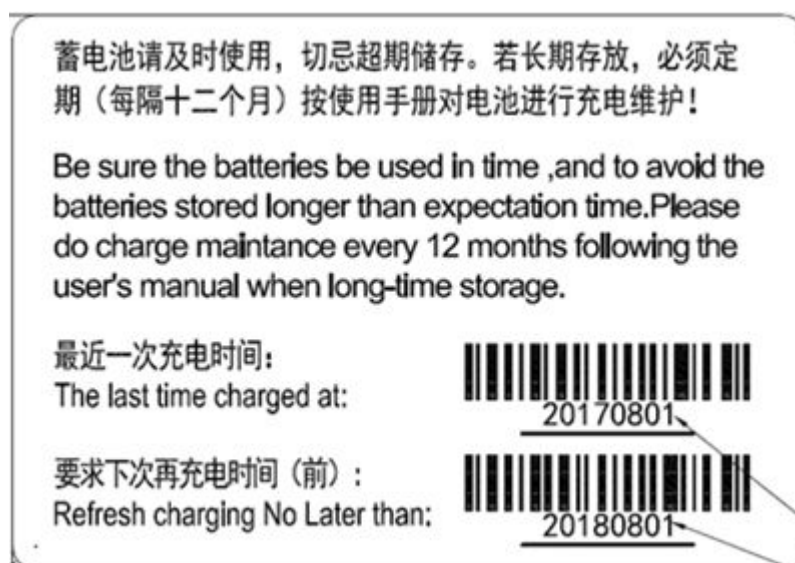

Storage Requirements



WARNING

- Ensure that batteries are stored in a dry, clean, and ventilated indoor environment that is free from sources of strong infrared or other radiations, organic solvents, corrosive gases, and conductive metal dust. Do not expose batteries to direct sunlight or rain and keep them far away from sources of heat and ignition.
- If a battery is faulty (with scorch, leakage, bulge, or water intrusion), move it to a dangerous goods warehouse for separate storage. The distance between the battery and any combustible materials must be at least 3 m. The battery must be scrapped as soon as possible.
- Place batteries correctly according to the signs on the packing case during storage. Do not place batteries upside down, lay them on one side, or tilt them. Stack batteries in accordance with the stacking requirements on the packing cases.
- Store batteries in a separate place. Do not store batteries together with other devices. Do not stack batteries too high. The site must be equipped with qualified fire fighting facilities, such as fire sand and fire extinguishers.

CAUTION

It is recommended that batteries be used soon after being deployed onsite. Batteries that have been stored for an extended period shall be charged periodically. Otherwise, they may be damaged.

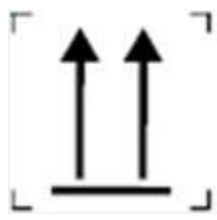
Table 29-3 Packaging label description

Picture	Description
	This way up: The package shall be vertically oriented during transport and storage.
	Fragile: The package contains fragile objects and shall be handled with care.

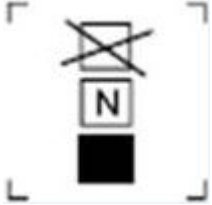
Picture	Description
	<p>Keep dry: The package shall be kept away from rain.</p>
	<p>Stacking limit by number: The packages shall not be vertically stacked beyond the specified number. The actual label may vary.</p>

- The storage environment requirements are as follows:
 - Ambient temperature: -40°C to $+60^{\circ}\text{C}$ (recommended: 20°C to 30°C)
 - Relative humidity: 5%–95% RH (recommended: about 45% RH)
 - Dry, clean, and well-ventilated
 - Away from corrosive organic solvents and gases
 - Away from direct sunlight
 - At least 2 meters away from heat sources
- The batteries in storage must be disconnected from external devices. The indicators (if any) on the batteries must be off.
- The storage duration starts from the latest charge time labeled on the battery package. If a battery is qualified after charge, update the latest charge time (recommended format: YYYY-MM-DD HH:MM) and the next charge time (Next charge time = Latest charge time + Charge interval) on the label.
- The total storage and transportation time of the battery packs shall not exceed eight months (starting from delivery). If it exceeds eight months, charge the batteries and calibrate the SOC to at least 50%. Otherwise, the battery performance and service life may be deteriorated.
- Do not unpack batteries. If charging is necessary, they must be charged by professionals as required and then returned to their original packaging after charging.
- The warehouse keeper shall collect battery storage information every month and periodically report the battery inventory information. The batteries in long-term storage shall be charged in a timely manner.

 **CAUTION**

- Only trained and qualified personnel are allowed to charge batteries. Wear insulated gloves and use dedicated insulated tools during the operation.
 - Observe onsite during charge and handle any exceptions in a timely manner.
 - If a battery experiences an abnormality such as bulging or smoking during charge, stop charging immediately and dispose of it.
-
- AC mains input voltage requirements for charging:
 - 220 V (three-phase 260–530 V AC or single-phase 176–300 V AC)
 - 110 V (three-phase 130–265 V AC or single-phase 90–175 V AC)
 - AC input power cables used for charging in the warehouse must have a through-current capacity greater than 23 A.
 - If batteries have been stored for longer than allowed, promptly report the event to the person in charge.
 - Ensure that batteries are delivered based on the "first in, first out" rule.
 - Handle batteries with caution to avoid damage.

Conditions for Determining Overdue Storage of Battery Packs

- Do not store batteries for extended periods.
- The total storage and transportation time of the battery packs shall not exceed eight months (starting from delivery). If it exceeds eight months, charge the batteries and calibrate the SOC to at least 50%. Otherwise, the battery performance and service life may be deteriorated.
- If batteries have been stored for longer than allowed, promptly report the event to the person in charge.
- Dispose of deformed, damaged, or leaking batteries directly irrespective of how long they have been stored.
- The storage duration starts from the latest charge time labeled on the battery package. If a battery is qualified after charge, update the latest charge time (recommended format: YYYY-MM-DD HH:MM) and the next charge time (Next charge time = Latest charge time + Charge interval) on the label.
- Charge batteries during storage once every eight months for a maximum of three times. Dispose of batteries if the maximum charge times are exceeded.

Preparing Charging Devices

- Multimeter
- Clamp meter
- Insulated torque socket wrench
- Charger

Inspection Before Charge

1. Before charging a battery, you need to check its appearance. Charge the qualified battery or dispose of the unqualified one.

2. The battery is qualified if it is free from the following symptoms:
 - Deformation
 - Shell damage
 - Leakage
3. Check that the accessories are complete based on the packing list delivered with the charger.

Full Charge Strategy

The charging ambient temperature ranges from 15°C to 40°C.

Charge and Discharge Current (Unit: Ampere)	Charging Duration (Excluding Equalization)
20	24 hours (fully discharge the battery and then charge the battery to 50% SOC)
40 ^[1]	12 hours (fully discharge the battery and then charge the battery to 50% SOC)
Note 1: In customized mode, use the AC 220 V/20 A (6 mm ²) power cable delivered with the charger.	

Charging Procedure

NOTE

Prepare the battery qualified for charge.

- Step 1** Connect the communications port on the charger to the COM-2 and 48V-2 ports on the battery using the CAN communications cable (48 V) delivered with the charger.
- Step 2** Connect the positive and negative cable ports on the charger to the positive and negative ports on the battery using the positive and negative DC input power cables delivered with the charger.
- Step 3** Connect the AC INPUT port on the charger to the utility power source using the power cable delivered with the charger.
- Step 4** Turn on the AC circuit breaker of the charger.
- Step 5** Turn on the DC circuit breaker of the charger.
- Step 6** Operate the charger according to its manual.
- Step 7** After the charge and discharge are complete, wait until the fan in the charger keeps running for about 5 minutes to dissipate the residual heat, turn off the AC and DC circuit breakers, and remove the cables.

----End

29.4 How Can I Export Device Logs?

Step 1 Access the device log page of the CMU or SmartLogger3000.

Figure 29-5 Log export

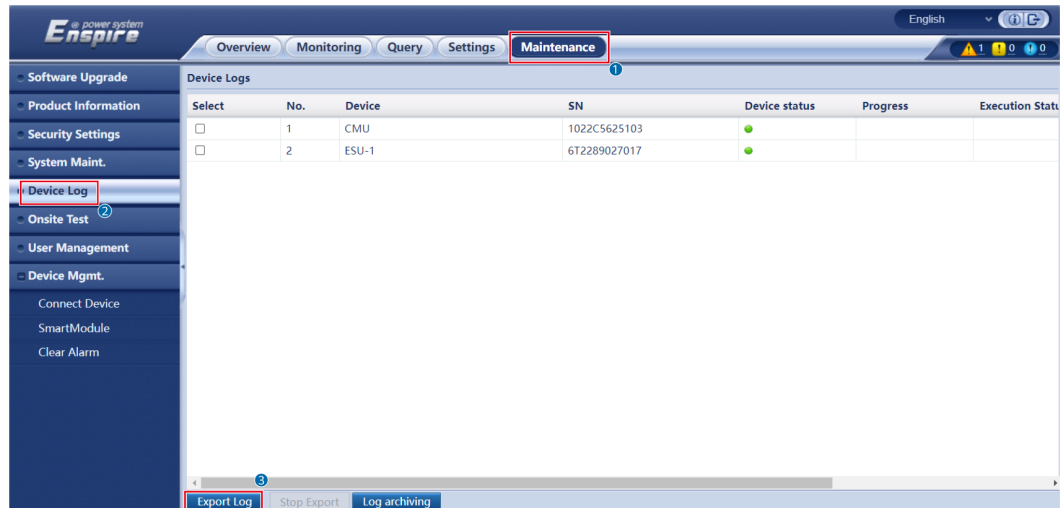

Step 2 Select the target device and click **Export Log**.

NOTE

- Logs of two or more types of devices cannot be exported at a time. For example, you cannot select both **SUN2000** and **MBUS**.
- Logs can be exported for a maximum of six devices of the same type at a time.
- Device log: Select the target device and click **Export Log**. The check box is displayed. You can select a specific log option.
- If the active power control mode is set to **Grid connection with limited power** or **Remote communication scheduling**, and the reactive power control mode is set to **Power factor closed-loop control** or the working mode of **Battery Control** is enabled, you are advised to export logs when inverters and Smart PCSs are disconnected from the grid. Otherwise, power control may be abnormal or the log export may fail.

Step 3 Observe the progress bar and wait until the log export is complete.

Step 4 After the export is successful, click **Log archiving** to save the logs.

----End

A Acronyms and Abbreviations

A

App application

B

BCU battery control unit

BMU battery monitoring unit

C

CAN control area network

CMU central monitoring unit

COM cluster communication
port

E

EPO emergency power-off

ESC smart rack controller

ESM battery pack

ESR battery rack

I

I/O input/output

N

NTC negative temperature
coefficient

P

PSU power supply unit

S

SACU smart array controller

SMU site monitoring unit

SOC state of charge

SOH state of health

T

TCU temperature control unit

U

UPS uninterruptible power
system